

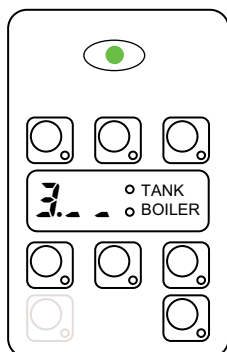

SERVICE MANUAL

**CONTENTS:**

This document contains the instructions to set electronic board parameters via user interface for following dishwashers:

CODE	MODEL	CODE	MODEL	CODE	MODEL	CODE	MODEL
400041	NUC3DD	400155	NUC1DPDD	504233	EHTAIG	506054	EPPWELG
400055	EUC1	502010	NUCAIG	504234	EHTAIWSG	506055	EPPWELG60
400056	EUC1DP	502011	NUCAIWSG	504235	EHTAIAU	506056	ZPPWELG
400057	EUC1WS	502025	EUCAI	504236	EHTAIMLAU	506057	ZPPWSLG
400058	EUC1DPWS	502026	EUCAIDP	504237	ZHTAWS	511326	NPPWESG
400059	EUC3	502027	EUCAI60	504238	ZHTAID	511328	NPPWEGH
400060	EUC3WS	502028	EUCAIWS	504239	ZHTAIWS	511329	NPPWELG
400061	EUC3DP	502033	EUCAIG	504240	ZHTAIAU	690028	NUC1G
400062	EUC3DPWS	502034	EUCAIWSG	504241	ZHTA	698005	NUCA1DDG
400063	EUC1G	502035	EUCAIML	504242	ZHTA60	698047	OHTAROW
400064	EUC1DP60	502036	EUCAIMLWS	504243	ZHTAI	698048	OHTAROW60
400065	EUC3DD	502037	EUCAIMLG	504244	EHTAIUSPH5	698049	NUCA1DPDDG
400066	ZUCADDROW	502038	EUCAICL	504245	EHTAIUSPH6	698058	NHTDPDDG
400067	ZUCADDROW6	502039	EUCAICLG	505036	EHTAO	698083	APPWELG
400068	EUCADD60	502040	EUCAIWL	505046	EHT	698085	APPWESG
400116	FUCA3DD	502042	EUCAICLW	505047	EHT60	698086	APPWEHG
400120	NUC1DPP	502043	EUCI	505048	EHTAG	698087	ET5AIT
400122	NUC1DUK	502044	EUCIM	505049	EHTM	698088	ET5AIDP
400123	NUC1DDUK	502045	EUCIM60	505050	EHTM60	698089	ET5AIDPWS
400127	KUC3	502046	EUCAIDPNW	505051	NHT	698091	AUCI
400128	KUC3DP	502047	ZUCI	505052	NHTD	698092	AUCAI
400130	NUC1DDRUKP	502048	ZUCID	505053	NHT60	698093	AUCAIDP
400131	NUC1GRUK	502049	ZUCAI	505054	EHTAROW	698094	AUCAIDPWS
400133	NUC1D	502050	ZUCAIDP	505055	EHTAROW60	698095	AUCAIG
400134	NUC1DD	502051	ZUCAIDPWS	505056	ZHTAROW	698096	AUCAIWSG
400137	EUCA1DP	502052	ZUCAIG	505057	ZHTAROW60	698097	ET12AI
400138	NUC1GMS	502053	ZUCAIDWS	505058	EHTAJ	698098	ET12AIT
400139	EUC3DPACAG	502054	ZUCAID	505059	EHTAJ60	698110	NHTAG
400140	NUC1	502055	ZUCAI60	505060	EHTAO60	698115	AHTAWS
400141	NUC1DP	502056	EUCAIUSPH6	505061	ZHTAO	698116	AHTAIWS
400142	NUC1WS	502057	ZUCAIDD	505062	ZHTAO60	698117	AHTAIG
400143	NUC1WSDP	502058	EUCAIDD	505063	KHT	698118	AHTAIWSG
400144	NUC3	502059	EUCAIDPJ	505064	NHTM	698119	AHTA
400145	NUC3WS	502060	EUCAIDPJ60	505065	NHTM60	698120	AHTAI
400146	NUC3DP	502123	EUCIDDC	505082	NHTP	S49JGF	
400147	NUC3DPWS	502124	ZUCIDC	505087	ZHT7	S49LBN	
400148	NUC3DDWS	504226	EHTA	505088	ZHT76	S49QL1	
400149	NUC1DP60	504227	EHTA60	506048	EPPWESG		
400150	NUC1DPA	504228	EHTAWS	506049	EPPWESG60		
400151	ZUCA1	504229	EHTAI	506050	EPPWEHG		
400152	ZUCA3	504230	EHTAID	506051	ZPPWESG		
400153	EUCADDROW	504231	EHTAIWS	506052	ZPPWEHG		
400154	EUCADDROW6	504232	EHTAIDWS	506053	ZPPWSSG		

EDITION:**12.2014**



INDEX

1	KEYBOARDS	Pag.	3
	1.1 HOOD TYPE Style	Pag.	3
	1.2 UNDERCOUNTER Style	Pag.	4
2	MANUAL ACTIVATION OF DETERGENT AND RINSE AID DISPENSERS	Pag.	5
	2.1 Detergent Dispenser Activation	Pag.	5
	2.2 Rinse Aid Dispenser Activation	Pag.	5
3	RINSE PUMP MANUAL ACTIVATION	Pag.	5
4	DETERGENT AND RINSE AID DOSAGE	Pag.	6
	4.1 GEn General Parameters	Pag.	6
5	COUNTERS	Pag.	8
	5.1 Cnt Counters	Pag.	8
6	TEMPERATURE SETTING	Pag.	10
	6.1 FAC Factory Parameters	Pag.	10
7	CYCLE SETTING	Pag.	12
	7.1 CYCLE DIAGRAM	Pag.	13
	7.2 CY1 Cycle 1 Parameters	Pag.	14
	7.3 CY2 Cycle 2 Parameters	Pag.	14
	7.4 CY3 Cycle 3 Parameters	Pag.	14
	7.5 drn Drain/Cleaning Cycle Parameters	Pag.	15
8	OTHER PARAMETERS	Pag.	15
	8.1 dPA Dishwashing Parameters	Pag.	15
	8.2 ron Read Only Parameters	Pag.	16
	8.3 HCP Communication and HACCP Parameters	Pag.	16
	8.4 CFG Configuration Parameters	Pag.	17
	8.5 dbG Parameters for automatic hood type dishwashers	Pag.	18
9	SPECIAL FEATURES	Pag.	20
	9.1 RESIN REGENERATION CYCLE	Pag.	20
	9.2 MEDICAL LINE DISHWASHER WITH DOOR/HOOD LOCK DEVICE	Pag.	20
	9.3 DETERGENT AND RINSE AID LEVEL SENSORS ACTIVATION	Pag.	20
	9.4 DISHWASHER WITH INCORPORATED CONTINUOUS WATER SOFTENER	Pag.	21
	9.5 HOOD-TYPE DISHWASHER WITH CYCLE THERMAL LABEL	Pag.	22
	9.6 DISHWASHERS WITH WASH TANK WATER CHANGE FREQUENCY CONTROL	Pag.	22
	9.7 PERISTALTIC TUBE FITTING AND REPLACEMENT INSTRUCTIONS	Pag.	23
10	MAIN BOARD CONFIGURATION	Pag.	26
	10.1 CODE -> Prog. TABLE	Pag.	26
	10.2 PROGRAMMING SHEETS	Pag.	28
11	DEFAULT VALUES	Pag.	120
12	USER INTERFACE AND MAIN BOARD CONNECTORS	Pag.	123
	12.1 Main malfunctions not due to the main board	Pag.	123
	12.2 CONNECTORS LAYOUT	Pag.	123
13	ALARM MESSAGES AND TROUBLESHOOTING	Pag.	130
	13.1 ALARMS THAT STOP THE DISHWASHER	Pag.	130
	13.1.1 ALARM CODES FOR AUTOMATIC HOOD TYPE DISHWASHERS	Pag.	130
	13.2 ALARMS THAT DON'T STOP THE DISHWASHER	Pag.	134
	13.3 ALARMS THAT DON'T STOP THE DISHWASHER FOR MODELS WITH INCORPORATED CONTINUOUS WATER SOFTENER	Pag.	136
14	LIST OF PARAMETERS FOR SUBSEQUENT VERSIONS	Pag.	137



1 KEYBOARDS

1.1 HOOD TYPE Style



Fig. 1 Detergent dispenser Manual Activation.



Fig. 2 Rinse Aid Dispenser Manual Activation

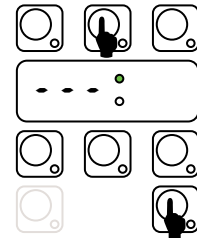

Fig. 3 Rinse Pump Manual Activation (used to EMPTY BOILER)

SETTING MODES:

To enter into one setting mode (Figure 4),(Figure 5) the appliance should be in stand-by: switch on the appliance, no cycles selected. Is useful keep door open to avoid start cycle in case of not simultaneously pressure of the two keys.

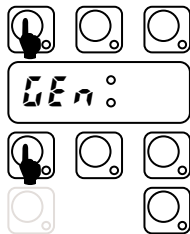

Fig. 4 Enter into General Parameters (Hold down buttons for at least five seconds).



Fig. 5 Enter into Factory Parameters (Hold down buttons for at least five seconds)..

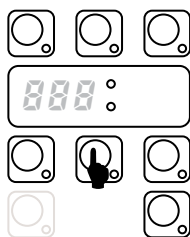

Fig. 6 Next Parameter Family OR Increase Parameter Value(In setting mode only)

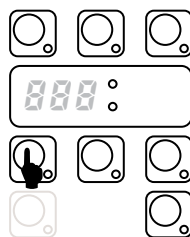

Fig. 7 Decrease Parameter Value(In setting mode only)

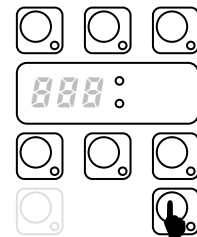

Fig. 8 Confirm Value and go to next Parameter (In setting mode only).



1.2 UNDERCOUNTER Style

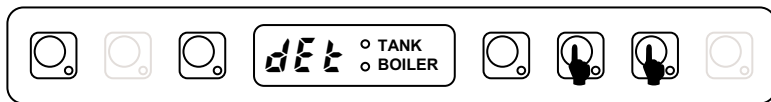

Fig. 9 Detergent dispenser Manual Activation

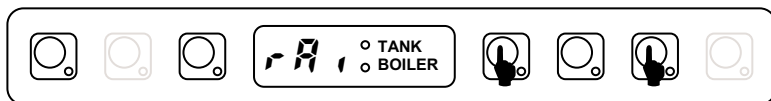

Fig. 10 Rinse Aid Dispenser Manual Activation

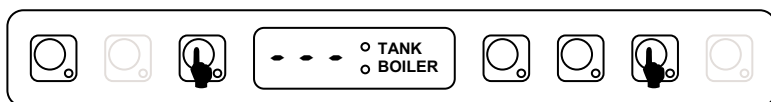

Fig. 11 Rinse Pump Manual Activation (used to EMPTY BOILER)

SETTING MODES:

To enter into one setting mode (Figure 12), (Figure 13) the appliance should be in stand-by: switch on the appliance, no cycles selected. Is useful keep door open to avoid start cycle in case of not simultaneously pressure of the two keys.

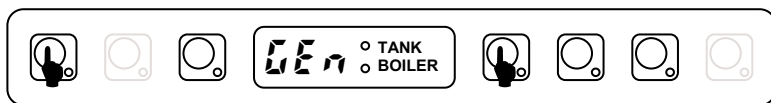

Fig. 12 Enter into General Parameters (Hold down buttons for at least five seconds).

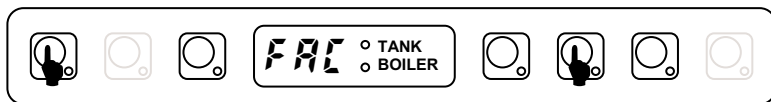

Fig. 13 Enter into Factory Parameters (Hold down buttons for at least five seconds).

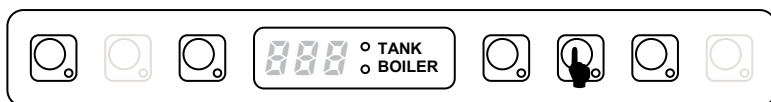

Fig. 14 Next Parameter Family OR Increase Parameter Value (in setting mode only)

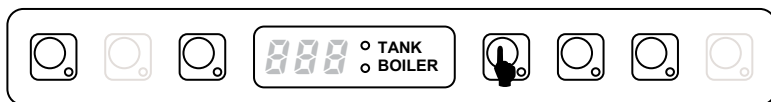

Fig. 15 Decrease Parameter Value (In setting mode only)

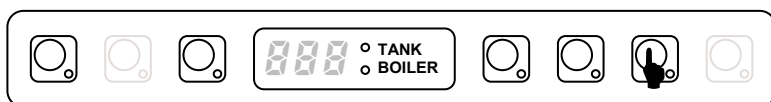

Fig. 16 Confirm Value and go to next Parameter (in setting mode only).



2 MANUAL ACTIVATION OF DETERGENT AND RINSE AID DISPENSERS

When replacing detergents may be necessary activate the dispensers to fill hoses.

2.1 Detergent Dispenser Activation

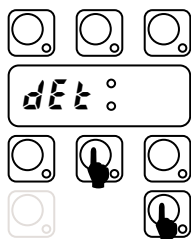

Switch on the dishwasher.

Press and hold down CYCLE_2 and CYCLE INFINITE keys, after two 'beep' the detergent dispenser starts work for 20 sec.

2.2 Rinse Aid Dispenser Activation

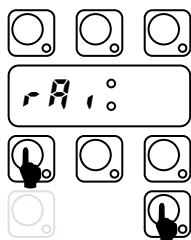

Switch on the dishwasher.

Press and hold down CYCLE_1 and CYCLE INFINITE keys, after two 'beep' the rinse aid dispenser starts work for 40 sec.

3 RINSE PUMP MANUAL ACTIVATION

Use this function to empty the boiler (if the dishwasher is not to be used for a long time, for maintenance operation: ex. before replacing main board).

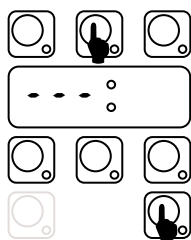

Switch on the dishwasher.

Close the door and press and hold down DRAIN and CYCLE INFINITE keys. A buzzer signal indicates the rinse pump activation and the display shows three blinking lines. Three beeps indicate the cycle end.



4 DETERGENT AND RINSE AID DOSAGE

In this paragraph is explained how to set the working time for the detergent and rinse aid dispensers. For each dispenser there are two parameters: the initial time and the time during cycle execution.

4.1 \mathcal{UEN} General Parameters

Sym.	Parameter Description	Unit	Min	Max	Factory Default
dIn	Initial Detergent Dosage (during filling tank)	[s]	0	240	90
rIn	Initial Rinse Aid Dosage (starts when tank filled)	[s]	0	180	10
dEt	Detergent Dosage During Cycle Execution (during wash phase)	[s]	0	182 (*)	8
rA	Rinse Aid Dosage During Cycle Execution (when refilling boiler)	[s]	0	62 (*)	4

How change the duration:

- Switch OFF and switch ON the dishwasher;
- Enter into the USER SETTING mode by pressing and hold down ON/OFF and CYCLE_1 keys for at least **five seconds** the display shows \mathcal{UEN} (Figure 17);
- Press CYCLE_INFINITE. The display shows alternatively the symbol dIn and the duration in seconds (Figure 18) and (Figure 19) ;
- NOTE: If User Interface v.3.00 tank led is on if value correspond to factory default (Default 1 - HOOD TYPE).
- Use CYCLE_1 key to decrease the duration and CYCLE_2 key to increase (Figure 19);
- After settled the duration press CYCLE_INFINITE key to **store value**. The display shows the next parameter (Figure 20) and the corresponding value (Figure 21);
- In the same way is possible to change the other duration; when finished switch OFF and switch ON.

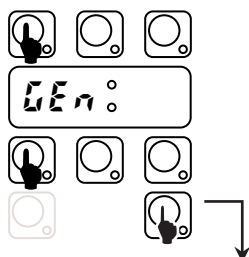

Fig. 17 Enter into User Mode (press for 5 sec)..

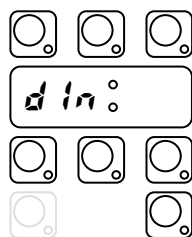

Fig. 18 Initial detergent dosage.



Fig. 19 Change duration. (Tank LED indicates default).



Fig. 20 Initial rinse aid dosage



Fig. 21 Change duration

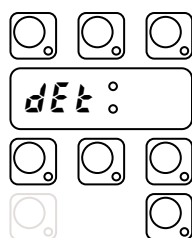

Fig. 22 Cycle detergent dosage.



Fig. 23 Change time activation (Tank LED indicates default)

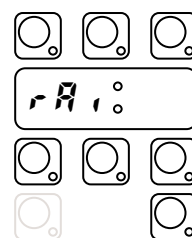

Fig. 24 Cycle rinse aid dosage.



Fig. 25 Change time activation.



(*) Note for external dispensers:

- if $dEt = 181$ the **detergent dispenser** works when **WASHING PUMP** is being activated; at the same time voltage is supplied between connectors **L17-L19** (main terminal box);
- if $dEt = 182$ the **detergent dispenser** works when **LOADING EV** is being activated to re-fill boiler level; at the same time voltage is supplied between connectors **L17-L19** (main terminal box);
- if $rA = 61$ the **rinse aid dispenser** works when **LOADING EV** is being activated to re-fill boiler level; at the same time voltage is supplied between connectors **L18-L19** (main terminal box);
- if $rA = 62$ the **rinse aid dispenser** works when **WASHING PUMP** is being activated; at the same time voltage is supplied between connectors **L18-L19** (main terminal box);

- For electrical connections refer to electric diagram -

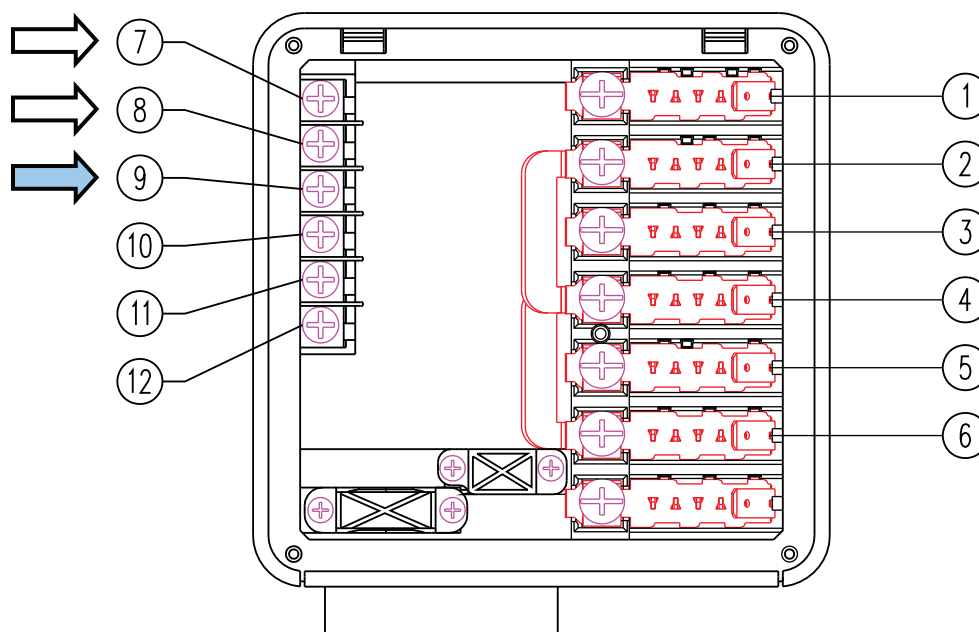

Example

Suppose there is connected an **external detergent dispenser** with a probe into the tank. A typical setting could be:

$dIn = 0$ the dispenser is not activated during filling tank;

$dEt = 181$ the dispenser is supplied during washing phase and the probe automatically dose the right detergent amount.



5 COUNTERS

This Parameter Family collects cycle counters and water consumption counters.

For water consumption counters a flow meter must be installed. See **PPL** (calibration parameter) into **dPR** section (8 OTHER PARAMETERS).

5.1 **Count** Counters

Sym.	Parameter Description	Unit	Min	Max	Factory Default
cyc	Cycles performed counter. cyc symbol and two numbers blink consecutively. The cycle number is obtained by joining the two numbers. Ex. cyc → 10 → 042 means 10042 cycles executed.	-			
cc	Cycle counter (resettable). This counter is similar to cyc but is resettable by user (see rSt parameter below).	-			
mcc	Water Consumption (only for dishwashers with incorporated continuous water softener). Counts m ³ of water consumption.	[m ³]			
l	Water Consumption (only for dishwashers with incorporated continuous water softener). Counts litres of water consumption. The total consumption is given by adding mcc [m ³] and l [l] values.	[l]			
lit	Water Consumption: resettable counter. [present up to software version 3.12] Counts the litres of water and is resettable by user (see rSt parameter below).	[l]			
rSt	Reset resettable counters: cc and lit To reset put 1 this parameter, switch off and then on again: cc and lit will show zero. Note that cyc is used to count cycles for EA! message (see next parameter, nCY).	-			
nCY	Store thousand of cycles after that EA! message appears on display. Ex. If this parameter is settled to 20, EA! message appears when cyc reach 20.000 cycles.	-			
drc	Drain/Cleaning cycles performed. Similar to cyc but counts Cleaning Cycles.	-			
rcy	Numbers of cycles that can be made after a regeneration cycle (only for dishwashers with non-continuous water softener) [See paragraph 9.1 RESIN REGENERATION CYCLE.].	-			20
rcE	Regeneration cycle counter (only for water softener dishwasher) [See paragraph 9.4 DISHWASHER WITH INCORPORATED CONTINUOUS WATER SOFTENER]. rcE only counts efficient regeneration cycles, i.e. those carried out with salt in the special container (only for dishwashers with incorporated continuous water softener)	-			
rcS	Counter of regeneration cycles done without salt in the special container. (only for dishwashers with incorporated continuous water softener) [See paragraph 9.4 DISHWASHER WITH INCORPORATED CONTINUOUS WATER SOFTENER].	-			

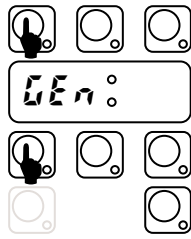

Fig. 26 USER setting mode
(press for 5s).



Fig. 27 Next Family

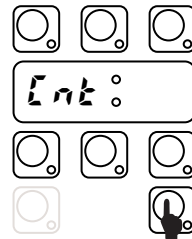

Fig. 28 Counters Fam.:
ENTER

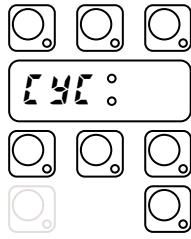

Fig. 29 CYCLES

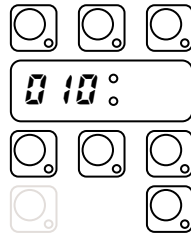

Fig. 30 Thousand.

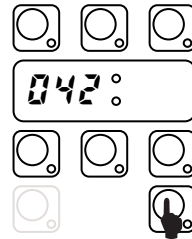

Fig. 31 Units.

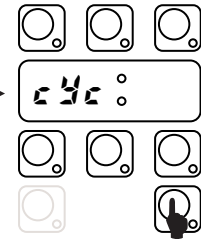

Fig. 32 Next counter.



6 TEMPERATURE SETTING

In this paragraph is explained how to change temperature thresholds and all parameters related to boiler and tank.

6.1 *FAL* Factory Parameters

Sym.	Parameter Description	Unit	Min	Max	Factory Default
<i>bE</i>	Boiler Temperature: THRESHOLD. When boiler temperature reaches this value, heaters switch off.	[°C]	45	95	78
<i>bEH</i>	Boiler Temperature HISTERESIS, (represent dead band). Heater switch on if boiler temperature is below: <i>bE</i> - <i>bEH</i>	[°C]	2	10	2
<i>bH</i>	Boiler Temperature: HIGH LIMIT. When boiler temperature reaches this value <i>E</i> 2 alarm appears. Put 0 to disable <i>E</i> 2 alarm.	[°C]	0	98	96
<i>bLo</i>	Boiler Temperature: LOW LIMIT. During boiler warm-up, temperature must increase at least <i>bLo</i> °C otherwise <i>E</i> 3 warning appears. Put 0 to disable <i>E</i> 3 warning.	[°C]	0	10	1
<i>bFL</i>	Boiler Filling Timeout. If filling time is longer than <i>bFL</i> , <i>A</i> 1 alarm appears. Put 0 to disable <i>A</i> 1 alarm.	[min]	0	42	5
<i>bAd</i>	Boiler Temperature Adjust.	[°C]	0	7	4
<i>bP</i>	Boiler Priority (enable boiler wait function) 0=disabled 1=enabled	-	0	1	1
<i>bSt</i>	Booster Function Overheat gap over Boiler Temperature Threshold	[°C]	0	15	2
<i>bEd</i>	Boiler temperature negative differential: when the dishwasher is in standby, boiler threshold becomes: <i>bE</i> - <i>bEd</i> (Used to save energy during machine inactivity by keeping boiler water at a lower temperature).	[°C]	0	20	0
<i>tE</i>	Tub Temperature: THRESHOLD When tank temperature reaches this value, heater switch off.	[°C]	40	85	63
<i>tEH</i>	Tub Temperature: HISTERESIS, (represent dead band). Heater switch on if tank temperature is below: <i>tE</i> - <i>tEH</i>	[°C]	2	30	5
<i>tH</i>	Tank Temperature: HIGH LIMIT. When tank temperature reaches this value <i>E</i> 3 alarm appears. Put 0 to disable <i>E</i> 3 alarm.	[°C]	0	95	75
<i>tLo</i>	Tank Temperature: LOW LIMIT. During tank warm-up, temperature must increase at least <i>tLo</i> °C otherwise <i>E</i> 2 warning appears. Put 0 to disable <i>E</i> 2 warning.	[°C]	0	10	1
<i>tFL</i>	Tank Filling Timeout. If filling time is longer than <i>tFL</i> , <i>A</i> 1 alarm appears. Put 0 to disable <i>A</i> 1 alarm.	[min]	0	42	20



To modify thresholds do the following:

- Switch OFF and switch ON the dishwasher;
- Enter into the FACTORY SETTING mode by pressing and hold down ON/OFF and CYCLE_2 keys for at least five seconds (Figure 33);
- Press CYCLE INFINITE. The display shows alternatively the symbol *bte* (Figure 34) and the corresponding value *75* (Figure 35);
- Use CYCLE_1 key to decrease the value and CYCLE_2 key to increase (Figure 35);
- Press CYCLE INFINITE key to confirm. The display shows the next parameter (Figure 36) and the corresponding value (Figure 37);
- In the same way is possible to change the other parameters; when finished switch OFF and switch ON.



Fig. 33 Factory setting mode.

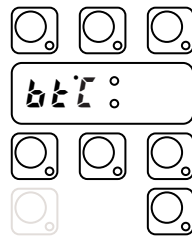

Fig. 34 Boiler temp. threshold

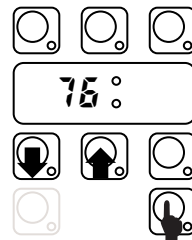

Fig. 35 Change value & Store

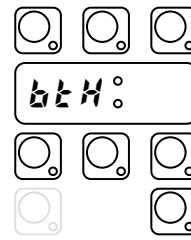

Fig. 36 Boiler Temp Hysteresis

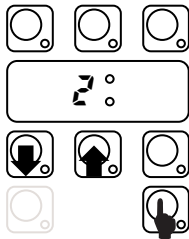

Fig. 37 Change value & Store

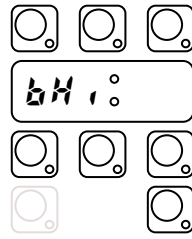

Fig. 38 Tank temp. High limit.



Fig. 39 Change value & Store.

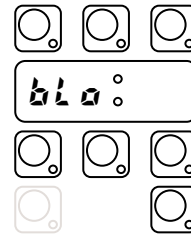

Fig. 41 Next Family

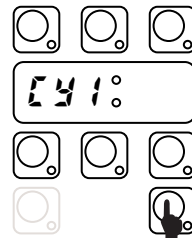

Fig. 42 Cycle 1 Family: ENTER.

At the end the display will show again *FAC* and by pressing CYCLE_2 key (Fig. 41) is possible to change cycle duration (see paragraph 7 CYCLE SETTING).

).



Fig. 40 Factory setting mode





7 CYCLE SETTING

In this paragraph is explained how to change cycle phases duration (see paragraph 7.1 CYCLE DIAGRAM).

- Switch on the dishwasher;
- Enter into the FACTORY SETTING mode: press and hold down ON/OFF and CYCLE_2 keys for at least **5 seconds** (Figure 43);
- Press CYCLE_2 key to select CYCLE_1 parameters.
- Press CYCLE_INFINITE. The display shows alternatively the symbol *Ln 1* (Figure 46) and the corresponding value *0* (Figure 47);
- Use CYCLE_1 key to increase the value and CYCLE_2 key to decrease (Figure 47);
- Press CYCLE_INFINITE key to confirm. The display shows the next parameter (Figure 48) and the corresponding value (Figure 49);
- In the same way is possible to change the other parameters;



Fig. 43 Factory setting mode.

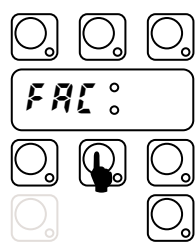

Fig. 44 Select next class.

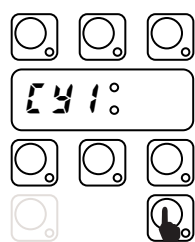

Fig. 45 Cycle 1 Family: ENTER.

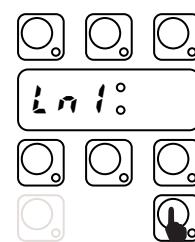

Fig. 46 Wash duration [min].

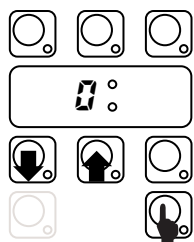

Fig. 47 Change value & Store

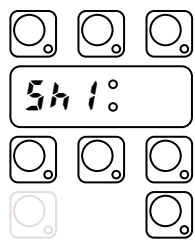

Fig. 48 Wash duration [sec].

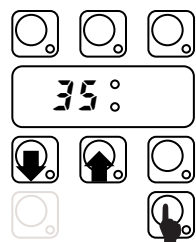

Fig. 49 Wash duration [min].

After settled all parameters referring Cycle 1, by pressing CYCLE_2 key is possible to change the Cycle 2 parameters (Figure 50), (Figure 51) and so on.

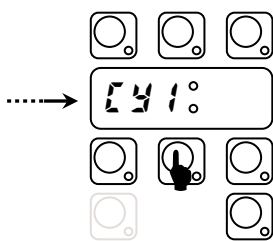

Fig. 50 Cycle 1 Parameters.

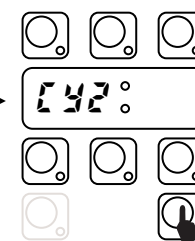

Fig. 51 Cycle 2 Parameters: ENTER.

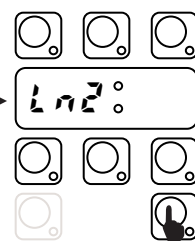

Fig. 52 Wash duration [min].

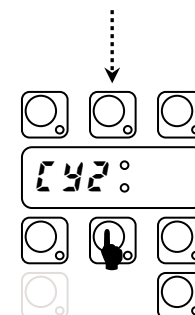

Fig. 53 Cycle 2 Parameters: next Family

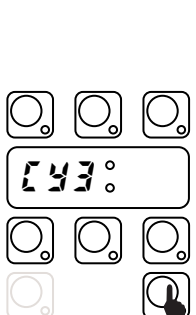

Fig. 54 Cycle 3 Parameters: ENTER

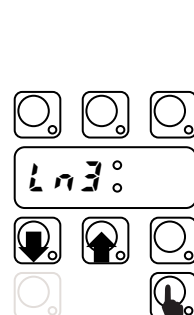
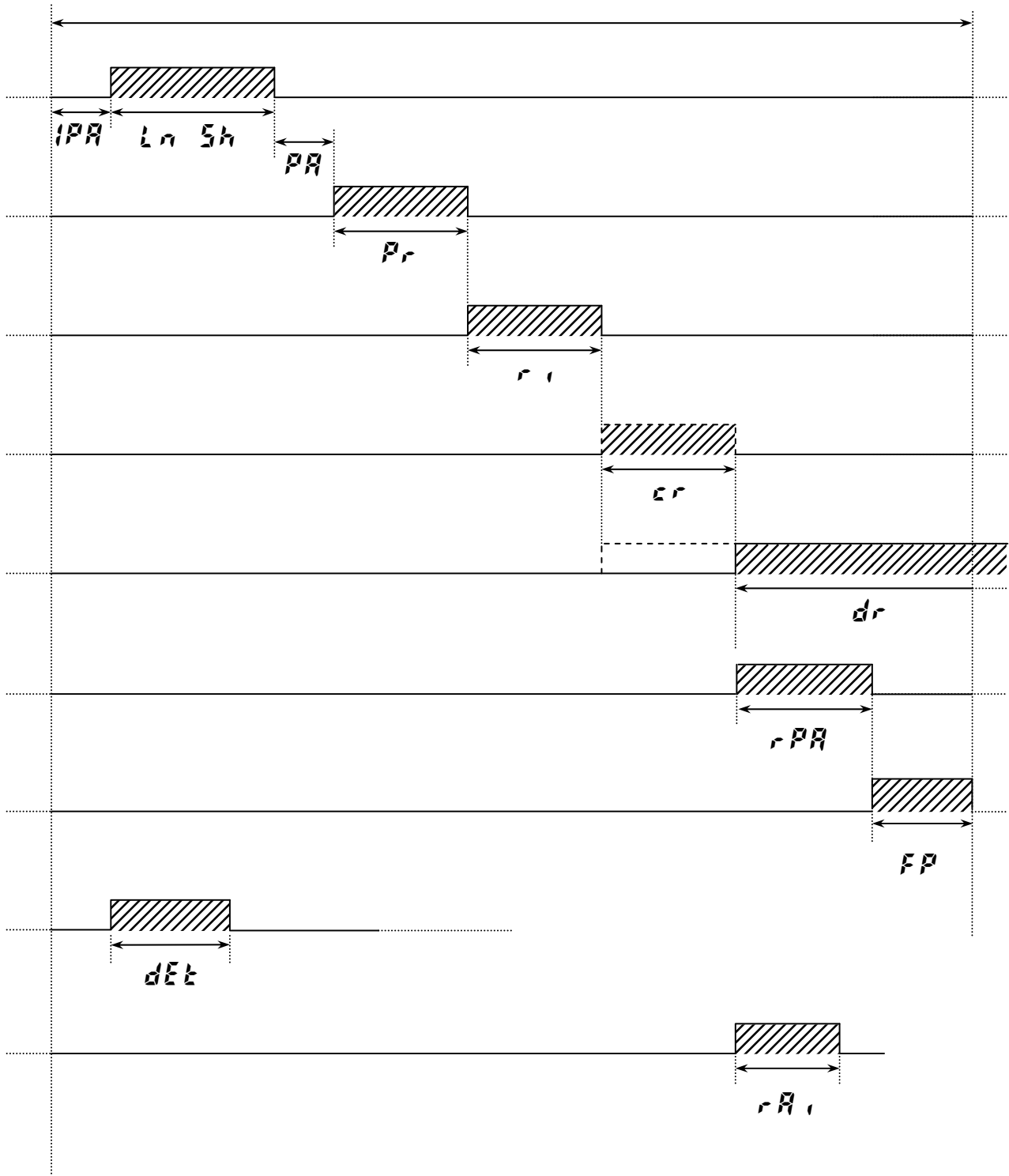

Fig. 55 Wash duration [min].



7.1 CYCLE DIAGRAM

CYCLE TYME



LEGENDA:

Ln Sh = wash

Pr = pre rinse

r i = rinse

cr = cold rinse

dr = drain

r PA = rinse pause

FP = final pause

dEt = detergent

r Ai = rinse aid

**7.2 [Y1] Cycle 1 Parameters**

Sym.	Parameter Description	Unit	Min	Max	Factory Default
Ln1	Wash Phase Long	[min]	0	20	0
Sh1	Wash Phase Short	[s]	1	60	35
PA1	Pause	[s]	0	20	4
Pr1	Pre-rinse Duration	[s]	0	30	0
r11	Rinse Phase Duration	[s]	10	45	16
cr1	Cold Rinse Phase Duration	[s]	0	50	0
dr1	Drain	[s]	0	40	16
FP1	Final Pause at End of Cycle	[s]	0	60	0
tL1	Long wash time in mode Thermal Label	[min]	0	60	0
tS1	Short wash time in mode Thermal Label	[s]	0	60	59

7.3 [Y2] Cycle 2 Parameters

Sym.	Parameter Description	Unit	Min	Max	Factory Default
Ln2	Wash Phase Long	[min]	0	20	0
Sh2	Wash Phase Short	[s]	1	60	45
PA2	Pause	[s]	0	20	4
Pr2	Pre-rinse Duration	[s]	0	30	0
r12	Rinse Phase Duration	[s]	10	45	16
cr2	Cold Rinse Phase Duration	[s]	0	50	0
dr2	Drain	[s]	0	40	16
FP2	Final Pause at End of Cycle	[s]	0	60	0
tL2	Long wash time in mode Thermal Label	[min]	0	60	1
tS2	Short wash time in mode Thermal Label	[s]	0	60	12

7.4 [Y3] Cycle 3 Parameters

Sym.	Parameter Description	Unit	Min	Max	Factory Default
Ln3	Wash Phase Long	[min]	0	20	1
Sh3	Wash Phase Short	[s]	1	60	40
PA3	Pause	[s]	0	20	4
Pr3	Pre-rinse Duration	[s]	0	30	0
r13	Rinse Phase Duration	[s]	10	45	16
cr3	Cold Rinse Phase Duration	[s]	0	50	0
dr3	Drain	[s]	0	40	16
FP3	Final Pause at End of Cycle	[s]	0	60	0
tL3	Long wash time in mode Thermal Label	[min]	0	60	2
tS3	Short wash time in mode Thermal Label	[s]	0	60	12
bt3	Boiler Temperature Threshold: only for Cycle 3. This parameter allows having a different rinsing temperature for the third cycle. Only values above 45°C are allowed.	[°C]	0	95	0



7.5 *drn* Drain/Cleaning Cycle Parameters

Sym.	Parameter Description	Unit	Min	Max	Factory Default
<i>idr</i>	Initial Drain Phase Duration	[s]	0	240	40
<i>fdr</i>	Final Drain Phase Duration	[s]	0	240	80
<i>drb</i>	Drain without cleaning cycle	-	0	1	0
<i>cbd</i>	Number of wash cycles possible between one drain cycle and the next	[wash cycles]	0	200	0
<i>dto</i>	Indicates the maximum permissible delay between drain cycle start and the reaching of a tank level below the work level. If the set delay is exceeded, alarm B1 occurs.	[s] x 10	0	100	18

8 OTHER PARAMETERS

8.1 *dpa* Dishwashing Parameters

Sym.	Parameter Description	Unit	Min	Max	Factory Default
<i>ipa</i>	Initial Pause before start washing (for ALL cycles)	[s]	0	10	0
<i>dly</i>	Delay for the 2 nd wash pump (PW only)	[s]	0	10	3
<i>pdr</i>	Active a drain phase at the end of washing phase.	[s]	0	40	0
<i>rpa</i>	Duration of pause after rinse cycle (valid for dishwashers with door/hood lock device) [See par. 9.2 MEDICAL LINE DISHWASHER WITH DOOR/HOOD LOCK DEVICE].	[s]	0	60	0
<i>cf</i>	Celsius/Fahrenheit selection 0 = Celsius 1 = Fahrenheit	-	0	1	0
<i>rit</i>	Rinse Temperature Display. Enable rinse temperature probe (if installed). 0 = during rinse phase the display shows boiler temperature; 1 = during rinse phase the display shows rinse temperature;	-	0	1	0
<i>ppl</i>	Pulse Per Litre. This parameter must be settled in according to flow meter installed [present up to software version 3.12].	[p/l]	0	255	0
<i>cde</i>	Number of wash cycles performable without detergent (only for dishwashers with external detergent level sensor – par. 9.3 DETERGENT AND RINSE AID LEVEL SENSORS ACTIVATION) [LES = 1]	-	0	5	5
<i>tle</i>	Enable mode Thermal Label: if set to 1 it enables the mode and disables the "endless cycle" button	-	0	1	0
<i>btl</i>	Boiler temperature in mode Thermal Label.	[°C]	45	97	86
<i>ttl</i>	Tank temperature in mode Thermal Label.	[°C]	40	90	75
<i>tht</i>	Tank temperature hysteresis in mode Thermal Label.	[°C]	0	30	2
<i>ile</i>	Pressure sensor threshold 1 [present up to software version 2.11].	-	0	255	140
<i>ih5</i>	Pressure sensor histeresis 1 [present up to software version 2.11].	-	0	255	50
<i>ile</i>	Pressure sensor threshold 2 [present up to software version 2.11].	-	0	255	140
<i>ih5</i>	Pressure sensor histeresis 2 [present up to software version 2.11].	-	0	255	50

Note: *ile*, *ih5*, *ile*, *ih5* parameters emulates a two levels pressure switch, keep in mind that value doesn't correspond to a physical quantity.

**8.2 *r o n* Read Only Parameters**

Sym.	Parameter Description	Unit	Min	Max	Factory Default
rEL	Main Board Firmware Release	-	-	-	-
rLS	Water softener board software version. (only for dishwashers with incorporated continuous water softener).	-	-	-	-
ACC	Active column: indicates through which of the two continuous water softener columns boiler filling is being carried out: 0 = column A and 1 = column B (only for dishwashers with incorporated continuous water softener).	-	-	-	-
ERR	When ERR message appears, the parameter value becomes 3. After maintenance, to clear ERR message, insert 0.	-	-	-	-
EB	When EB alarm appears, the machine is frozen and this parameter is 3. After maintenance (see alarm codes document), insert 0 to enable the machine.	-	-	-	-
F21	This alarm appears in case of malfunctioning in the continuous water softener. To facilitate fault-finding, see par. 13.3 ALARMS THAT DON'T STOP THE DISHWASHER FOR MODELS WITH INCORPORATED CONTINUOUS WATER SOFTENER.	-	-	-	-

8.3 *HCP* Communication and HACCP Parameters

Sym.	Parameter Description	Unit	Min	Max	Factory Default
SEr	Serial Device 0 = 8N1 1 = PC connection (DAAS 8E1) 7 = HACCP network (ECAP 8E1+LK485) (LK485 board is necessary) 9 = Dishwashers with incorporated continuous water softener 16 = HACCP printer (8N1) 32 = MODEM GSM (DAAS 8N1) 33 = MODEM GSM (DAAS 8E1) 48 = Hyper Terminal (8N1)	-	0	63	1
Adr	Address. This parameter specifies the address of the appliance into the 'HACCP_network'. Works only if 'HACCP network' is selected (see above parameter).	-	0	255	1
Prn	Print parameter table.	-	0	1	1
bE	HACCP 'Basic' (printer) Boiler temperature: high limit.	[°C]	45	95	90
bH	HACCP 'Basic' (printer) Boiler temperature: gap below high limit.	[°C]	0	20	10
tE	HACCP 'Basic' (printer) Tank temperature: high limit.	[°C]	35	75	68
tH	HACCP 'Basic' (printer) Tank temperature: gap below high limit.	[°C]	0	20	10



8.4 *CFG* Configuration Parameters

Sym.	Parameter Description	Unit	Min	Max	Factory Default
<i>typ</i>	Dishwasher Model: 0 = HOOD TYPE & UNDERCOUNTER 1 = POT WASHER 2 = AUTOMATIC POT WASHER 3 = MEDICAL LINE DISHWASHER WITH LOCK DOOR/HOOD DEVICE	-	0	3	0
<i>boi</i>	Boiler type: 0 = ATMOSPHERIC BOILER 1 = PRESSURE BOILER 2 = EXTERNAL BOILER	-	0	2	0
<i>doa</i>	Door type: 0 = AUTOMATIC HOOD 1 = MANUAL HOOD 2 = FRONT LOADING 3 = POT WASHER		0	3	1
<i>dfi</i>	Default model (see Default tables): 1 = HOOD TYPE 2 = POT WASHER 3 = UNDERCOUNTER	-	0	3	-
<i>trc</i>	Solid State Relay (TRIAC). 0 = not enabled; 1 = SOFT START enabled; 3 = SLOW SOFT START enabled (works only on boards with Solid State Relay).	-	0	3	0
<i>b-t</i>	Boiler/Tank heating swap: 0 = boiler heaters and tank heater can work simultaneously; 1 = swap enabled: tank heating starts only boiler temperature is reached; 2 = The booster heating elements and the wash pump have priority. The tank heating element is activated only when the booster has reached the set temperature and the wash pump is not working. (Note: disabling this function changes the global electrical power of appliance; before enabling this function check available power, supply cable section, fuses in according to User Manual).	-	0	2	1
<i>btf</i>	Tank Filling Mode Enable filling tank by means of rinsing cycles. Ex: <i>btf</i> = 75 means that boiler water is heated at 75°C, then follows a rinse phase and so on until tank is full. If <i>btf</i> = 0 the tank is filled by solenoid valve in the traditional way (On machines with incorporated continuous water softener, even if <i>btf</i> is set to 0, filling occurs through subsequent rinses).	[°C]	0	85	75
<i>les</i>	Detergent Level Switches 0 = level switches not enabled; 1 = enable detergent level switches;	-	0	1	0



USER INTERFACE MODEL

8 = ACTIVE function disabled (**up to version 3.11 [up to serial nr. 42100099] set to 0**)

9 = hood type, under counter (**up to version 3.11 [up to serial nr. 42100099] set to 1**)

U I

13 = LS5 with atmospheric boiler(**up to version 3.11 [up to serial nr. 42100099] set to 5**)

15 = LS5 with pressure boiler (user interface without display); (**up to version 3.11 [up to serial nr. 42100099] set to 7**)

24 = LS5 with atmospheric boiler (**From Ser. Nr.: 821**).

See parameter **r E L** (family **r a r**) to check the software version installed in the board.

- 0 27 9

Sym.	Parameter Description	Unit	Min	Max	Factory Default
r E	Enable "regeneration cycle" key (only for dishwashers with non-continuous water softener) [See paragraph 9.1 RESIN REGENERATION CYCLE].	-	0	1	0
ALARMS ENABLE					
AL r	0 = alarms disabled (to disable also warnings see b L a and t L a); 1 = alarms enabled; If this function is disabled, faults can be detected so display do not shows any alarm code.	-	0	1	1
AA G	Air gap with float level sensor normally closed (the level sensor is closed when the boiler is empty). E.g. the boiler level sensor for machines with incorporated continuous water softener.	-	0	1	0
F r G	Forced start of a resin regeneration cycle (only for dishwashers with incorporated continuous water softener). [See paragraph 9.4 DISHWASHER WITH INCORPORATED CONTINUOUS WATER SOFTENER].	-	0	2	0
S r U	Max. rinse water hardness (only for dishwashers with incorporated continuous water softener). After modifying, disconnect and reconnect the machine's main power supply by means of the main switch. [See paragraph 9.4 DISHWASHER WITH INCORPORATED CONTINUOUS WATER SOFTENER].	°fH	4	14	10
b P a	Boiler heating control. Defines the max. permissible temperature difference during boiler heating in a time interval of 2 minutes and 30 seconds.	°C	25	80	50

8.5 **db G** Parameters for automatic hood type dishwashers

Sym.	Parameter Description	Unit	Min	Max	Factory Default
t 1	DELAY_K1 Time (during hood lifting) within which S3" must return to the rest position.	0.1 s	0.0 s	20.0 s	15
t 2	HOOD_TOUT TIMEOUT – max. time allowed for complete hood opening/closing.	0.1 s	0.0 s	20.0 s	200
t 3	DELAY_K1_S3 During hood lowering, firstly S3" must cut in and then after a time t 3 .the bottom limit switch S3.	0.1 s	0.0 s	20.0 s	15
t 4	DELAY_K Time within which K and K' must be both closed or both open.	0.1 s	0.0 s	20.0 s	10
t 5	DELAY_S3 Time during hood lifting within which the bottom limit switch must return to the rest position..	0.1 s	0.0 s	20.0 s	20



t 5	DELAY_S5 Time during hood lowering within which the top limit switch must return to the rest position.	0.1 s	0.0 s	20.0 s	20
AL -	Displays the last alarm code relative to automatic hood type dishwashers.	-	-	-	0
ilh	Parameter only valid for hood type models. Hood lifting motor absorption threshold. (50 units correspond to a current of approx. 1 ampere).	-	0	250	100



9 SPECIAL FEATURES

9.1 RESIN REGENERATION CYCLE



The regeneration cycle is activated by pressing the button shown in the figure, for at least 5 seconds.

For this key to be enabled parameter *rE* (in family *LFU*) must be set to 1.

At this point you can enter the number of wash cycles that can be performed after each regeneration: parameter *rCY* in the counters family *Ent*. If *rCY* is set to zero the counter is disabled, otherwise after the preset number of cycles the message *rEU* is displayed to confirm that regeneration is possible (this is an information-only message with no effect on operation of the appliance, so you can continue to use the dishwasher). The message is cleared when the regeneration cycle is terminated.

The number of regeneration cycles performed can be checked by consulting the parameter *nrE* in the *Ent* family of counters.

When there are just 15 cycles remaining before the next regeneration cycle, at the end of the wash cycle the display shows the message *End* followed by *15*, at the end of the next wash cycle the display shows *End* and *14*, and so forth, i.e. the display informs the user of the number of wash cycles still available before resin regeneration is required.

Before starting the regeneration cycle remove the siphon spillway.

WARNING:

If the regeneration cycle is accidentally started, it can be switched off by pressing the button shown in the figure, for at least 5 seconds

The hardness of the water exiting the softener can vary between 3°f - 10 °f / 1.7 °d - 5.6 °d / 2.1 °e - 7 °e.

9.2 MEDICAL LINE DISHWASHER WITH DOOR/HOOD LOCK DEVICE

The medical line dishwasher with door/hood lock device has a device that prevents door/hood opening for the entire duration of the work cycle.

For the door/hood lock to be active, the parameter *tYP* (in the *LFU* family) must be set to *3*.

The dishwasher door/hood is locked at the start of a wash cycle and is released at the end of the final pause after rinse. The wash compartment can be accessed by stopping the work cycle in progress, as the locking device is thus disabled. .

A pause at the end of rinse can be set by means of the parameter *rPA* (in the *dPA* family). This parameter is common to all 3 wash cycles. The rinse water temperature is displayed during this pause. Another final pause in the cycle can be set by setting the parameters *FP1*, *FP2*, *FP3*. During the final pause the display shows the time remaining for completion of the cycle. The door/hood lock device will be deactivated at the end of the final pause (*FP1*, *FP2*, *FP3*).

For correct performance of the wash cycle the pause at the end of rinse and the final pause must assume the default values (see Prog 032 – 034 - 035).

9.3 DETERGENT AND RINSE AID LEVEL SENSORS ACTIVATION

By setting the parameter *LES* (in the *LFU* family) to 1, management of the level sensors located inside the external detergent and rinse aid tanks is enabled. During the rinse phase, when the rinse aid inside the tank has finished, the message *rA, 0* appears on the display.

When the detergent inside the tank is finished, the message *dEt 0* is displayed and after a number of wash cycles equal to *LDL* (in the *dPA* family) the dishwasher inhibits the activation of other wash cycles. Therefore the detergent level in the tank must be restored.



9.4 DISHWASHER WITH INCORPORATED CONTINUOUS WATER SOFTENER

Dishwashers with incorporated continuous water softener have a continuous softener in the water circuit. By means of special resins, this device removes the calcareous substances from the feed water, supplying decalcified water for washing.

To activate the continuous water softener, set the parameter *SER* (in the *HEP* family) to the value *9*.

For the continuous softener to work properly the resins must be regenerated periodically with a frequency depending on the hardness of the inlet water, the number of wash cycles carried out and the max. hardness set with the parameter *SrU* (in the *EEG* family).

Unlike conventional water softeners, this continuous softener does not require machine stops for regenerating the resins.

To regenerate the resins it is necessary to put coarse salt in the special container located in the dishwasher. In particular, the salt container must be filled when the dishwasher is started the first time and whenever the message *SAL End* appears on the display and an audible alarm sounds. The salt container holds up to 1.5 kg of salt

WARNING:

Use only coarse salt with a NaCl purity grade of 99.8 %. The use of salt with a lower purity grade may cause the salt container filter to clog and the water softener to malfunction.

WARNING:

The message *SAL End* may appear, for several rinse, tank filling or wash cycles, even after replenishing the salt, as the salt must circulate in the entire system. This, however, does not affect correct dishwasher operation.

The number of regeneration cycles performed can be checked by consulting the parameter *nrE* in the *Ent* family of counters.

nrE only counts regeneration cycles carried out with the salt container adequately filled; there is another counter, *rES* (in the *Ent* family) that indicates the number of regeneration cycles done without salt.

If the parameter *SrU* is set to the value 10, according to the factory setting, the water softener outlet water hardness can vary between 3°f - 10 °f / 1.7 °d - 5.6 °d / 2.1 °e - 7 °e.

AUTONOMY OF THE FULL SALT CONTAINER ACCORDING TO THE CHANGE IN INLET WATER HARDNESS

Water hardness			The salt container must be filled approximately every (*):	Using cycle 2 for 30 cycles/day, the salt container must be filled approximately every (*):
°f	°d	°e	Cycles	Days
15	8,4	10,5	1168	39
20	11,2	14	837	28
25	14	17,5	589	19
30	16,8	21,1	506	17
35	19,6	24,6	423	14
40	22,4	28,1	341	11

(*) Considering a rinse time according to the factory settings.

Maximum outlet water hardness can be modified by setting the *SrU* value. The outlet water hardness can be modified from the value of 4° f to 14° f.

NB: To save the new water hardness value, in addition to the normal parameter modification and saving operations it is necessary to disconnect and reconnect the machine's main power supply by means of the main switch on the external board.

Water softener operation can be checked by forcing the regeneration of resins, without waiting for the outlet water hardness to reach the set max. value (*SrU*).



To do this, wait for the water softener to finish previous resin washing or regeneration operations and set the parameter $F r \bar{U}$ ($\bar{U} F \bar{U}$ family) to $\bar{1}$ for regenerating column A or to $\bar{2}$ for regenerating column B.

Switch the machine off and on again so that it carries out complete regeneration of the set column. If previous resin washing or regeneration operations were not completed, the manual request for regeneration is not carried out.

It is possible to check which column is being used for boiler filling by querying the parameter $R R \bar{L}$ ($r o n$ family): if $R R \bar{L} = 0$ column "A" is used, if $R R \bar{L} = 1$ column "B" is used.

The number of litres used by the machine can be checked by querying the parameters $n n c$ (m3) and \bar{L} (litres). To calculate the total number of litres used by the machine, add the $n n c$ and \bar{L} values.

NB: In machines with incorporated continuous water softener, tank filling must be done through subsequent rinses from the boiler and cannot occur by overflow since the filling system does not allow overflow in the tank. Therefore, even if the parameter $b \bar{t} F$ is set to $\bar{0}$, filling is done by subsequent rinses..

9.5 HOOD-TYPE DISHWASHER WITH CYCLE THERMAL LABEL

WARNING:

Functions present with firmware version 4.04.

If the parameter $\bar{t} \bar{L} \bar{E}$ (Thermal Label enabled) of the family $d P A$ is set to $\bar{0}$, the "Endless cycle" button has the "endless cycle" function and the "high productivity" mode is non-settable.

If the parameter $\bar{t} \bar{L} \bar{E}$ (Thermal Label enabled) of the family $d P A$ is set to $\bar{1}$, the "Endless cycle" button does not have the "endless cycle" function but that of the "high productivity" mode.

This means that the machine can work in 2 modes, "high productivity" and "Thermal Label". When the machine is set in "high productivity" mode, the parameters which define the cycle times and temperature set points are the standard parameters, whereas when the machine is set in "Thermal Label" mode, the parameters are dedicated (they are new parameters listed below).

The mode Thermal Label provides for cycle times, tank hysteresis and tank and boiler temperatures such as to pass the "Thermal Label" test.

Press and hold down the button to switch the machine from "high productivity" mode to "Thermal Label" mode and vice versa.

The "high productivity" button LED is off when the machine is set in "Thermal Label" mode (factory default) and lights up when the button is pressed and the machine is configured in "high productivity" mode. Whenever the machine is shut down, it memorises the mode with which it was switched off and reloads it when switched on the next time.

New parameters:

- $\bar{t} \bar{L} \bar{E}$ (family $d P A$): if set to $\bar{1}$ it enables the Thermal Label mode (and disables the "endless cycle" button).
- $b \bar{t} \bar{L}$ (family $d P A$): temperature set point for the boiler during the cycles Thermal Label.
- $\bar{t} \bar{L} \bar{L}$ (family $d P A$): temperature set point for the tank during the cycles Thermal Label.
- $\bar{t} \bar{H} \bar{L}$ (family $d P A$): hysteresis temperature for the tank during the cycles Thermal Label.
- $\bar{t} \bar{L} \bar{1}$ (family $\bar{L} \bar{Y} \bar{1}$): long wash time for cycle 1 in Thermal Label mode.
- $\bar{t} \bar{S} \bar{1}$ (family $\bar{L} \bar{Y} \bar{1}$): short wash time for cycle 1 in Thermal Label mode.
- $\bar{t} \bar{L} \bar{2}$ (family $\bar{L} \bar{Y} \bar{2}$): long wash time for cycle 2 in Thermal Label mode.
- $\bar{t} \bar{S} \bar{2}$ (family $\bar{L} \bar{Y} \bar{2}$): short wash time for cycle 2 in Thermal Label mode.
- $\bar{t} \bar{L} \bar{3}$ (family $\bar{L} \bar{Y} \bar{3}$): long wash time for cycle 3 in Thermal Label mode.
- $\bar{t} \bar{S} \bar{3}$ (family $\bar{L} \bar{Y} \bar{3}$): short wash time for cycle 3 in Thermal Label mode.

9.6 DISHWASHERS WITH WASH TANK WATER CHANGE FREQUENCY CONTROL

WARNING:

Function included starting from firmware version 5.00.



If the parameter ξ_{bd} (Cycles before drain) of the family drn is set to a value higher than ξ , a wash tank water change frequency control is enabled. The purpose of this function is to display a message telling the customer when a tank water drain cycle is required. In this way, if the customer does what the machine suggests, washes will be done with sufficiently clean water.

The value set in the parameter ξ_{bd} (Cycles before drain) indicates the number of wash cycles possible between one tank water drain cycle and the next. When the number of wash cycles done since the last tank water change reaches the value contained in the parameter ξ_{bd} (Cycles before drain), the display shows the message “ drn ” at the start of a wash cycle and the message “ $drn\ End$ ” at the end of the same cycle. When these messages appear on the display at the start and end of the wash cycle, a tank water drain cycle must be done to ensure washes with sufficiently clean water.

WARNING:

If the tank drain cycle is not done, the machine does not shut down, but will continue to do wash cycles, showing the messages drn and $drn\ End$ at the start and end of the wash cycle respectively.

9.7 PERISTALTIC TUBE FITTING AND REPLACEMENT INSTRUCTIONS

Described below is the procedure for inserting and removing the tubes from the peristaltic pumps, in case of tube replacement.

An exploded view of the parts involved in the tube fitting and removal operations is given below.

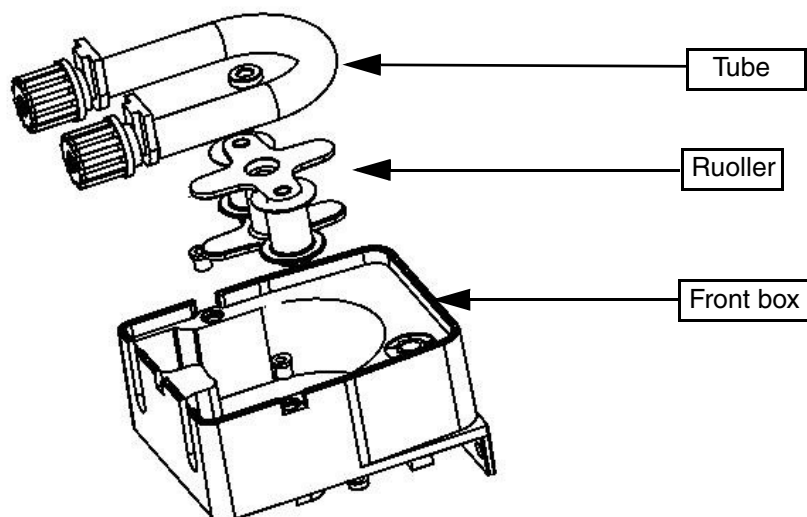



STEP 1 - FITTING THE TUBE

1. Position the roller.

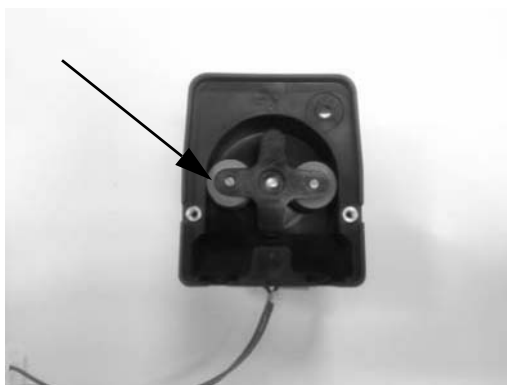

2. Insert the tube of the suction part, turning the roller clockwise.

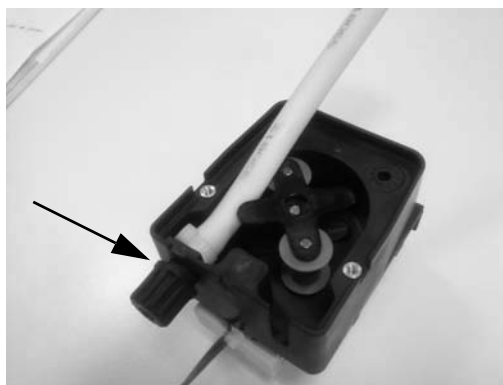

3. Keep the tube in the seat in the housing and continue turning the roller clockwise, being careful not to damage the tube.

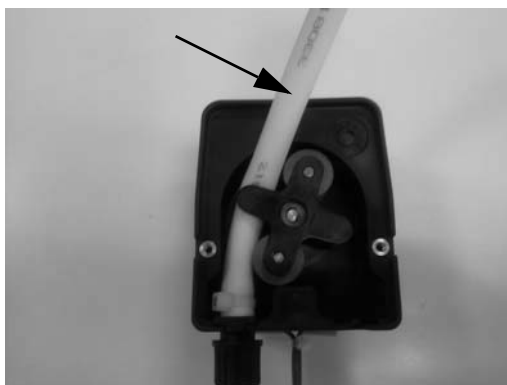

4. Keep the tube in the seat in the housing and continue turning the roller clockwise.

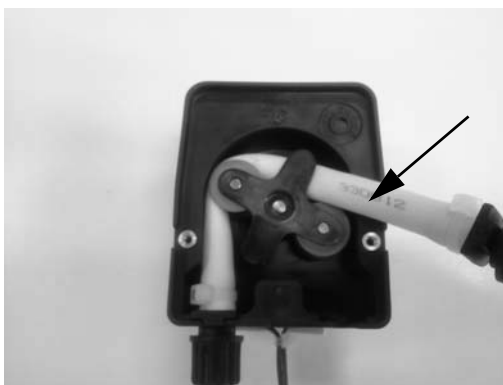

5. Turn the roller a full 360°.



6. Make sure to fit the union in the special seat (delivery).

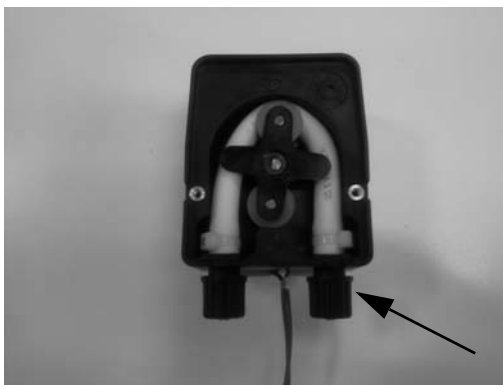



STEP 2 - REMOVING THE TUBE

1. Position the roller as shown in the figure.

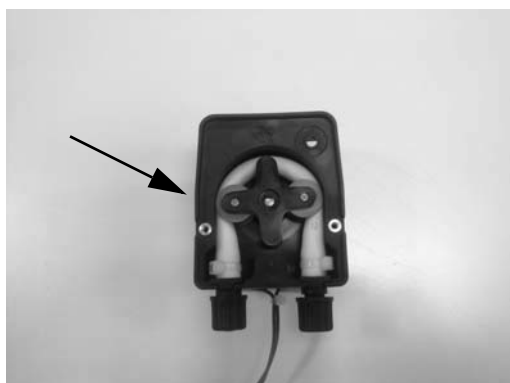

2. Lift the tube at the suction part and turn the roller at the same time. Guide the tube, keeping it raised, and turn the roller.

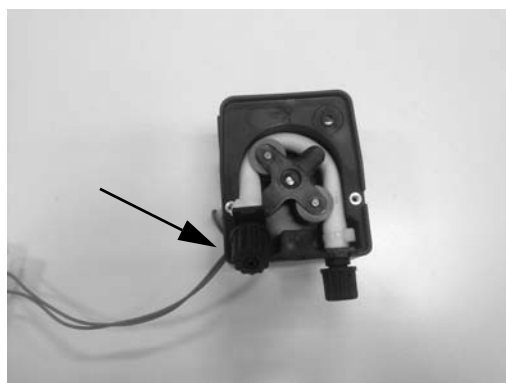

3. Remove the tube.

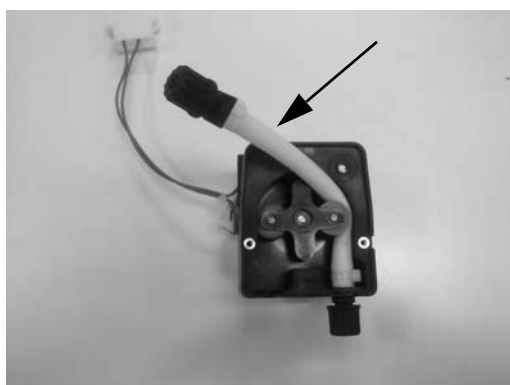



10 MAIN BOARD CONFIGURATION

When receiving an electronic board (spare part) may be necessary to configure it in according to the machine where has to be replaced

4. With the machine **CODE** enter into the following table and read the corresponding **Prog.** number
5. Follow the instructions reported into the corresponding **Prog.XXX** sheet (next pages).
6. With the machine **CODE** find the **Layout** number in Par. 12.2 CONNECTORS LAYOUT.

10.1 CODE -> Prog. TABLE

MODEL	CODE	Prog.	Layout
NUC3DD	400041	103	16
EUC1	400055	101	11
EUC1DP	400056	101	11
EUC1WS	400057	102	21
EUC1DPWS	400058	102	21
EUC3	400059	103	16
EUC3WS	400060	104	17
EUC3DP	400061	103	16
EUC3DPWS	400062	104	17
EUC1G	400063	105	11
EUC1DP60	400064	101	11
EUC3DD	400065	103	16
ZUCADDROW	400066	134	16
ZUCADDROW6	400067	134	16
EUCADD60	400068	143	16
FUCA3DD	400116	135	16
NUC1DPP	400120	101	11
NUC1DUK	400122	101	11
NUC1DDUK	400123	101	11
KUC3	400127	103	16
KUC3DP	400128	103	16
NUC1DDRUKP	400130	146	11
NUC1GRUK	400131	136	16
NUC1	400133	101	11
NUC1DD	400134	101	11
EUCAIDP	400137	128	11
NUC1GMS	400138	137	11
EUC3DPCAG	400139	138	16
NUC1	400140	101	11
NUC1DP	400141	101	11
NUC1WS	400142	102	21
NUC1WSDP	400143	102	21
NUC3	400144	103	16
NUC3WS	400145	104	17
NUC3DP	400146	103	16
NUC3DPWS	400147	104	17
NUC3DDWS	400148	104	17
NUC1DP60	400149	101	11
NUC1DPA	400150	105	11
ZUCA1	400151	128	11
ZUCA3	400152	128	16
EUCADDROW	400153	134	16
EUCADDROW6	400154	134	16
NUC1DPDD	400155	101	11
NUCAIG	502010	106	8
NUCAIWSG	502011	107	8

MODEL	CODE	Prog.	Layout
EUCAI	502025	106	8
EUCAIDP	502026	106	8
EUCAI60	502027	106	8
EUCAIWS	502028	107	8
EUCAIG	502033	106	8
EUCAIWSG	502034	107	8
EUCAIML	502035	108	8
EUCAIMLWS	502036	109	8
EUCAIMLG	502037	110	10
EUCAICL	502038	111	18
EUCAICLG	502039	111	18
EUCAIWL	502040	112	8
EUCAICLW	502042	113	18
EUCI	502043	114	16
EUCIM	502044	115	19
EUCIM60	502045	115	19
EUCAIDPNW	502046	106	8
ZUCI	502047	114	16
ZUCID	502048	114	16
ZUCAI	502049	106	8
ZUCAIDP	502050	106	8
ZUCAIDPWS	502051	107	8
ZUCAIG	502052	106	8
ZUCAIDWS	502053	107	8
ZUCAID	502054	106	8
ZUCAI60	502055	106	8
EUCAIUSPH6	502056	125	9
ZUCAIDD	502057	106	8
EUCAIDD	502058	106	8
EUCAIDPJ	502059	106	8
EUCAIDPJ60	502060	106	8
EUCIDDC	502123	145	16
ZUCIDC	502124	145	16
EHTA	504226	120	1
EHTA60	504227	120	1
EHTAWS	504228	121	4
EHTAI	504229	120	1
EHTAID	504230	120	4
EHTAIWS	504231	121	4
EHTAIDWS	504232	121	4
EHTAIG	504233	120	4
EHTAIWSG	504234	121	4
EHTAIAU	504235	122	15
EHTAIMLAU	504236	123	4
ZHTAWS	504237	121	4
ZHTAID	504238	120	4
ZHTAIWS	504239	121	4



MODEL	CODE	Prog.	Layout
ZHTAIAU	504240	122	15
ZHTA	504241	120	4
ZHTA60	504242	120	4
ZHTAI	504243	120	4
EHTAIUSPH5	504244	126	2
EHTAIUSPH6	504245	126	2
EHTAO	505036	124	23
EHT	505046	118	13
EHT60	505047	118	13
EHTAG	505048	119	23
EHTM	505049	118	13
EHTM60	505050	118	13
NHT	505051	118	13
NHTD	505052	118	13
NHT60	505053	118	13
EHTAROW	505054	124	23
EHTAROW60	505055	124	23
ZHTAROW	505056	124	23
ZHTAROW60	505057	124	23
EHTAJ	505058	120	23
EHTAJ60	505059	120	23
EHTAO60	505060	124	23
ZHTAO	505061	124	23
ZHTAO60	505062	124	23
KHT	505063	118	13
NHTM	505064	118	13
NHTM60	505065	118	13
NHTP	505082	118	13
ZHT7	505087	144	23
ZHT76	505088	144	23
EPPWESG	506048	139	4
EPPWESG60	506049	141	4
EPPWEHG	506050	139	4
ZPPWESG	506051	139	4
ZPPWEHG	506052	139	4
ZPPWSSG	506053	139	4
EPPWELG	506054	140	4
EPPWELG60	506055	142	4
ZPPWELG	506056	140	4
ZPPWSLG	506057	140	4
NPPWESG	511326	139	4
NPPWEHG	511328	139	4
NPPWELG	511329	140	4
NUC1G	690028	105	11
NUCA1DDG	698005	136	16
OHTAROW	698047	127	23
OHTAROW60	698048	127	23
NUCA1DPDDG	698049	136	16
NHTDPDDG	698058	119	23
APPWELG	698083	140	4
APPWESG	698085	139	4
APPWEHG	698086	139	4
ET5AIIT	698087	131	8
ET5AIDP	698088	132	8
ET5AIDPWS	698089	133	8

MODEL	CODE	Prog.	Layout
AUCI	698091	114	16
AUCAI	698092	116	8
AUCAIDP	698093	116	8
AUCAIDPWS	698094	117	8
AUCAIG	698095	106	8
AUCAIWSG	698096	107	8
ET12AI	698097	129	4
ET12AIT	698098	130	4
NHTAG	698110	119	23
AHTAWS	698115	121	4
AHTAIWS	698116	121	4
AHTAIG	698117	120	4
AHTAIWSG	698118	121	4
AHTA	698119	120	4
AHTAI	698120	120	4
	S49JGF	103	16
	S49LBN	103	16
	S49QL1	103	16



10.2 PROGRAMMING SHEETS

NUC1 / EUC1		PROG 101
1. Switch OFF and then switch ON the machine.		
2. CFG Enter into CFG parameter family and set the following parameters:		
	tYP	0 Hood Type and undercounter.
	bo1	1 Pressure boiler.
	doo	2 Front loading function.
	dFl	3 Default values for Undercounter models.
	trc	0 Disabled (for this appliance SOFT START is NOT possible).
	b.t	1 Tank heater works only if boiler temperature reached.
	b.tF	0 The tank is filled into the traditional way.
	LES	0 Detergent level switches not enabled.
	U1	24 Select user interface for LS5.
	rE	0 Regeneration cycle disabled.
	Alr	0 Alarms not enabled.
	RAE	0 Boiler electronic level sensor.
	FrC	0 Resin regeneration cycle forcing.
	SrU	10 Rinse water max. hardness.
	bPo	50 Boiler heating control.
3. Switch OFF and then switch ON the machine.		
4. Modify Factory parameters:		
FAC Enter into FAC parameter family and set the following parameters.		
	b.tC	82 Boiler Temperature Threshold.
	b.H1	96 Boiler temperature: alarm threshold.
	b.AJ	3 Boiler Temperature Adjust.
	b.P	1 Boiler standby function enabled.
	b.St	2 Booster Function.
	b.td	3 During stand-by boiler is kept at lower temperature than Temperature Threshold.
	t.tC	63 Tub Temperature: Threshold.
	t.H1	75 Tank temperature: alarm threshold.
5. Modify the cycle parameters:		
CY1 Cycle 1 parameters family.		
	L.n1	1 Long Wash Phase [min].
	S.h1	40 Short Wash Phase [s].
	P.A1	4 Pause [s].
	r.i1	16 Rinse Phase Duration [s].
	d.r1	30 Drain [s].
	F.P1	0 Final Pause [s].
CY2 Cycle 2 parameters family.		
	L.n2	2 Long Wash Phase [min].
	S.h2	40 Short Wash Phase [s].
	P.A2	4 Pause [s].
	r.i2	16 Rinse Phase Duration [s].
	d.r2	30 Drain [s].
	F.P2	0 Final Pause [s].
CY3 Cycle 3 parameters family.		
	L.n3	2 Long Wash Phase [min].
	S.h3	40 Short Wash Phase [s].
	P.A3	4 Pause [s].
	r.i3	16 Rinse Phase Duration [s].
	d.r3	30 Drain [s].
	F.P3	0 Final Pause [s].
	b.t3	0 Boiler Temperature Threshold for Cycle 3.

**NUC1 / EUC1****PROG 101**

drn	Drain parameters family.	
idr	30	Initial Drain Phase Duration [s].
fdr	100	Final Drain Phase Duration [s].
drt	0	Drain and cleaning mode.
cbd	0	Wash tank water change frequency control disabled.
dPA	Set other parameters.	
ipa	0	Initial Pause [s] (for ALL cycles).
dly	3	Delay for the 2 nd wash pump [s].
pdr	0	Drain Phase Duration at the end of washing phase [s].
rPA	0	Duration of pause after the rinse cycle [s] (for ALL cycles).
CF	0	Degrees Celsius display.
rit	0	During the rinse stage, the display shows the boiler temperature.
HCP	Enter into HCP parameter family and set the following parameters.	
SEr	1	Machine arranged for remote connection to PC.
6. Switch OFF and then switch ON the machine.		
GEr	Enter into GEn parameter family.	
dIn	165	Initial Detergent Dosage.
rIn	0	Initial Rinse Aid Dosage.
dEt	182	Detergent dispenser works when LOAD SOLENOID VALVE in activated.
rA i	61	Rinse Aid dispenser works when LOAD SOLENOID VALVE in activated.
7. Switch OFF and then switch ON the machine.		

WARNING:

To set the board parameters , carefully follow the order given in this programming file, from point 1 to point 7.

WARNING:

When modifying parameter **dFL** , all the parameters (except those belonging to the **CFG** family) assume the default values according to the tables in section 11 DEFAULT VALUES. The parameters of the **CFG** family are not modified.



NUC1WS / EUC1WS

PROG 102

1. Switch OFF and then switch ON the machine.

2. **CFG** Enter into CFG parameter family and set the following parameters:

tYP	0	Hood Type and undercounter.
bo i	0	Atmospheric boiler.
dao	2	Front loading function.
dFl	3	Default values for Undercounter models.
trc	0	Disabled (for this appliance SOFT START is NOT possible).
b_t	1	Tank heater works only if boiler temperature reached.
btF	75	Enable filling tank by means of rinsing cycles.
LES	0	Detergent level switches not enabled.
U1	24	Select user interface for LS5.
rE	1	Regeneration cycle enabled.
Al r	0	Alarms not enabled.
AAE	0	Boiler electronic level sensor.
FrE	0	Resin regeneration cycle forcing.
SrU	10	Rinse water max. hardness.
bPo	50	Boiler heating control.

3. Switch OFF and then switch ON the machine.

4. Modify Factory parameters:

FAC Enter into FAC parameter family and set the following parameters.

btE	83	Boiler Temperature Threshold.
bH i	96	Boiler temperature: alarm threshold.
BAJ	2	Boiler Temperature Adjust.
bP	1	Boiler standby function enabled.
bSt	2	Booster Function.
bt d	3	During stand-by boiler is kept at lower temperature than Temperature Threshold.
ttE	63	Tub Temperature: Threshold.
tH i	75	Tank temperature: alarm threshold.

5. Modify the cycle parameters:

CY1 Cycle 1 parameters family.

Ln1	1	Long Wash Phase [min].
Sh1	40	Short Wash Phase [s].
PA1	4	Pause [s].
r i1	16	Rinse Phase Duration [s].
dr1	30	Drain [s].
FP1	0	Final Pause [s].

CY2 Cycle 2 parameters family.

Ln2	2	Long Wash Phase [min].
Sh2	40	Short Wash Phase [s].
PA2	4	Pause [s].
r i2	16	Rinse Phase Duration [s].
dr2	30	Drain [s].
FP2	0	Final Pause [s].

CY3 Cycle 3 parameters family.

Ln3	2	Long Wash Phase [min].
Sh3	40	Short Wash Phase [s].
PA3	4	Pause [s].
r i3	16	Rinse Phase Duration [s].
dr3	30	Drain [s].
FP3	0	Final Pause [s].
bt3	0	Boiler Temperature Threshold for Cycle 3.



NUC1WS / EUC1WS		PROG 102
drn	Drain parameters family.	
idr	30	Initial Drain Phase Duration [s].
fdr	100	Final Drain Phase Duration [s].
drt	0	Drain and cleaning mode.
lbd	0	Wash tank water change frequency control disabled.
dPA	Set other parameters.	
ipa	0	Initial Pause [s] (for ALL cycles).
dly	3	Delay for the 2 nd wash pump [s].
pdr	0	Drain Phase Duration at the end of washing phase [s].
rPA	0	Duration of pause after the rinse cycle [s] (for ALL cycles).
CF	0	Degrees Celsius display.
rit	0	During the rinse stage, the display shows the boiler temperature.
HCP	Enter into HCP parameter family and set the following parameters.	
SEr	1	Machine arranged for remote connection to PC.
6. Switch OFF and then switch ON the machine.		
GEr	Enter into GEn parameter family.	
dIn	70	Initial Detergent Dosage.
rIn	5	Initial Rinse Aid Dosage.
dEt	8	Detergent dispensing during the wash cycle (loading during wash stage).
rA,	4	Rinse aid dispensing during the rinse cycle (loading during boiler filling stage).
7. Switch OFF and then switch ON the machine.		

WARNING:

To set the board parameters , carefully follow the order given in this programming file, from point 1 to point 7.

WARNING:

When modifying parameter *dFL* , all the parameters (except those belonging to the *CFG* family) assume the default values according to the tables in section 11 DEFAULT VALUES. The parameters of the *CFG* family are not modified.



NUC3 / KUC3 / EUC3

PROG 103

1. Switch OFF and then switch ON the machine.

2. **CFG** Enter into CFG parameter family and set the following parameters:

tyP	0	Hood Type and undercounter.
boi	1	Pressure boiler.
dao	2	Front loading function.
dFl	3	Default values for Undercounter models.
trc	1	SOFT START enabled.
b.t	1	Tank heater works only if boiler temperature reached.
b.tF	0	The tank is filled into the traditional way.
LES	0	Detergent level switches not enabled.
U1	24	Select user interface for LS5.
rE	0	Regeneration cycle disabled.
Alr	0	Alarms not enabled.
AAc	0	Boiler electronic level sensor.
FrC	0	Resin regeneration cycle forcing.
SrU	10	Rinse water max. hardness.
bPo	50	Boiler heating control.

3. Switch OFF and then switch ON the machine.

4. Modify Factory parameters:

FAC Enter into FAC parameter family and set the following parameters.

b.tC	84	Boiler Temperature Threshold.
bH1	96	Boiler temperature: alarm threshold.
bAJ	3	Boiler Temperature Adjust.
bP	1	Boiler standby function enabled.
bSt	2	Booster Function.
b.td	3	During stand-by boiler is kept at lower temperature than Temperature Threshold.
t.tC	63	Tub Temperature: Threshold.
t.H1	75	Tank temperature: alarm threshold.

5. Modify the cycle parameters:

CY1 Cycle 1 parameters family.

Ln1	1	Long Wash Phase [min].
Sh1	40	Short Wash Phase [s].
PA1	4	Pause [s].
r.i1	16	Rinse Phase Duration [s].
dr1	30	Drain [s].
FP1	0	Final Pause [s].

CY2 Cycle 2 parameters family.

Ln2	2	Long Wash Phase [min].
Sh2	40	Short Wash Phase [s].
PA2	4	Pause [s].
r.i2	16	Rinse Phase Duration [s].
dr2	30	Drain [s].
FP2	0	Final Pause [s].

CY3 Cycle 3 parameters family.

Ln3	2	Long Wash Phase [min].
Sh3	40	Short Wash Phase [s].
PA3	4	Pause [s].
r.i3	16	Rinse Phase Duration [s].
dr3	30	Drain [s].
FP3	0	Final Pause [s].
b.t3	0	Boiler Temperature Threshold for Cycle 3.



NUC3 / KUC3 / EUC3		PROG 103
drn	Drain parameters family.	
idr	30	Initial Drain Phase Duration [s].
fdr	100	Final Drain Phase Duration [s].
drt	0	Drain and cleaning mode.
lbd	0	Wash tank water change frequency control disabled.
dPA	Set other parameters.	
ipa	0	Initial Pause [s] (for ALL cycles).
dly	3	Delay for the 2 nd wash pump [s].
pdr	0	Drain Phase Duration at the end of washing phase [s].
rPA	0	Duration of pause after the rinse cycle [s] (for ALL cycles).
CF	0	Degrees Celsius display.
rit	0	During the rinse stage, the display shows the boiler temperature.
HCP	Enter into HCP parameter family and set the following parameters.	
SEr	1	Machine arranged for remote connection to PC.
6. Switch OFF and then switch ON the machine.		
GE_n	Enter into GEn parameter family.	
dln	165	Initial Detergent Dosage.
rin	0	Initial Rinse Aid Dosage.
dEt	182	Detergent dispenser works when LOAD SOLENOID VALVE in activated.
rA_i	61	Rinse Aid dispenser works when LOAD SOLENOID VALVE in activated.
7. Switch OFF and then switch ON the machine.		

WARNING:

To set the board parameters , carefully follow the order given in this programming file, from point 1 to point 7.

WARNING:

When modifying parameter **dFL** , all the parameters (except those belonging to the **CFG** family) assume the default values according to the tables in section 11 DEFAULT VALUES. The parameters of the **CFG** family are not modified.



NUC3WS / EUC3WS

PROG 104

1. Switch OFF and then switch ON the machine.

2. **CFG** Enter into CFG parameter family and set the following parameters:

tyP	0	Hood Type and undercounter.
boi	0	Atmospheric boiler.
dao	2	Front loading function.
dFl	3	Default values for Undercounter models.
trc	1	SOFT START enabled.
b.t	1	Tank heater works only if boiler temperature reached.
btF	75	Enable filling tank by means of rinsing cycles.
LES	0	Detergent level switches not enabled.
U1	24	Select user interface for LS5.
rE	1	Regeneration cycle enabled.
Alr	0	Alarms not enabled.
AAc	0	Boiler electronic level sensor.
FrC	0	Resin regeneration cycle forcing.
SrU	10	Rinse water max. hardness.
bPo	50	Boiler heating control.

3. Switch OFF and then switch ON the machine.

4. Modify Factory parameters:

FAC Enter into FAC parameter family and set the following parameters.

btC	83	Boiler Temperature Threshold.
bH1	96	Boiler temperature: alarm threshold.
BAJ	2	Boiler Temperature Adjust.
bP	1	Boiler standby function enabled.
bSt	2	Booster Function.
btD	3	During stand-by boiler is kept at lower temperature than Temperature Threshold.
tC	63	Tub Temperature: Threshold.
tH1	75	Tank temperature: alarm threshold.

5. Modify the cycle parameters:

CY1 Cycle 1 parameters family.

Ln1	1	Long Wash Phase [min].
Sh1	40	Short Wash Phase [s].
PA1	4	Pause [s].
ri1	16	Rinse Phase Duration [s].
dr1	30	Drain [s].
FP1	0	Final Pause [s].

CY2 Cycle 2 parameters family.

Ln2	2	Long Wash Phase [min].
Sh2	40	Short Wash Phase [s].
PA2	4	Pause [s].
ri2	16	Rinse Phase Duration [s].
dr2	30	Drain [s].
FP2	0	Final Pause [s].

CY3 Cycle 3 parameters family.

Ln3	2	Long Wash Phase [min].
Sh3	40	Short Wash Phase [s].
PA3	4	Pause [s].
ri3	16	Rinse Phase Duration [s].
dr3	30	Drain [s].
FP3	0	Final Pause [s].
bt3	0	Boiler Temperature Threshold for Cycle 3.

**NUC3WS / EUC3WS****PROG 104**

drn	Drain parameters family.	
idr	30	Initial Drain Phase Duration [s].
fdr	100	Final Drain Phase Duration [s].
drt	0	Drain and cleaning mode.
lbd	0	Wash tank water change frequency control disabled.
dPA	Set other parameters.	
ipa	0	Initial Pause [s] (for ALL cycles).
dly	3	Delay for the 2 nd wash pump [s].
pdr	0	Drain Phase Duration at the end of washing phase [s].
rPA	0	Duration of pause after the rinse cycle [s] (for ALL cycles).
CF	0	Degrees Celsius display.
rit	0	During the rinse stage, the display shows the boiler temperature.
HCP	Enter into HCP parameter family and set the following parameters.	
SEr	1	Machine arranged for remote connection to PC.
6. Switch OFF and then switch ON the machine.		
GE_n	Enter into GEn parameter family.	
dIn	70	Initial Detergent Dosage.
rIn	5	Initial Rinse Aid Dosage.
dEt	8	Detergent dispensing during the wash cycle (loading during wash stage).
rA_i	4	Rinse aid dispensing during the rinse cycle (loading during boiler filling stage).
7. Switch OFF and then switch ON the machine.		

WARNING:

To set the board parameters , carefully follow the order given in this programming file, from point 1 to point 7.

WARNING:

When modifying parameter **dFL** , all the parameters (except those belonging to the **CFG** family) assume the default values according to the tables in section 11 DEFAULT VALUES. The parameters of the **CFG** family are not modified.



NUC1G / EUC1G

PROG 105

1. Switch OFF and then switch ON the machine.

2. **CFG** Enter into CFG parameter family and set the following parameters:

tYP	0	Hood Type and undercounter.
boi	1	Pressure boiler.
dao	2	Front loading function.
dFl	3	Default values for Undercounter models.
trc	0	Disabled (for this appliance SOFT START is NOT possible).
b.t	1	Tank heater works only if boiler temperature reached.
b.tF	0	The tank is filled into the traditional way.
LES	0	Detergent level switches not enabled.
U1	24	Select user interface for LS5.
rE	0	Regeneration cycle disabled.
Alr	0	Alarms not enabled.
AAE	0	Boiler electronic level sensor.
FrG	0	Resin regeneration cycle forcing.
SrU	10	Rinse water max. hardness.
bPo	50	Boiler heating control.

3. Switch OFF and then switch ON the machine.

4. Modify Factory parameters:

FAC Enter into FAC parameter family and set the following parameters.

b.tC	82	Boiler Temperature Threshold.
bH1	96	Boiler temperature: alarm threshold.
bAJ	3	Boiler Temperature Adjust.
bP	1	Boiler standby function enabled.
bSt	2	Booster Function.
b.td	3	During stand-by boiler is kept at lower temperature than Temperature Threshold.
t.tC	63	Tub Temperature: Threshold.
t.H1	75	Tank temperature: alarm threshold.

5. Modify the cycle parameters:

CY1 Cycle 1 parameters family.

Ln1	1	Long Wash Phase [min].
Sh1	40	Short Wash Phase [s].
PA1	4	Pause [s].
r.i1	16	Rinse Phase Duration [s].
dr1	30	Drain [s].
FP1	0	Final Pause [s].

CY2 Cycle 2 parameters family.

Ln2	2	Long Wash Phase [min].
Sh2	40	Short Wash Phase [s].
PA2	4	Pause [s].
r.i2	16	Rinse Phase Duration [s].
dr2	30	Drain [s].
FP2	0	Final Pause [s].

CY3 Cycle 3 parameters family.

Ln3	2	Long Wash Phase [min].
Sh3	40	Short Wash Phase [s].
PA3	4	Pause [s].
r.i3	16	Rinse Phase Duration [s].
dr3	30	Drain [s].
FP3	0	Final Pause [s].
b.t3	0	Boiler Temperature Threshold for Cycle 3.

**NUC1G / EUC1G****PROG 105**

drn	Drain parameters family.	
idr	30	Initial Drain Phase Duration [s].
fdr	100	Final Drain Phase Duration [s].
drt	0	Drain and cleaning mode.
cbd	0	Wash tank water change frequency control disabled.
dPA	Set other parameters.	
ipa	0	Initial Pause [s] (for ALL cycles).
dly	3	Delay for the 2 nd wash pump [s].
pdr	0	Drain Phase Duration at the end of washing phase [s].
rPA	0	Duration of pause after the rinse cycle [s] (for ALL cycles).
CF	0	Degrees Celsius display.
rit	0	During the rinse stage, the display shows the boiler temperature.
HCP	Enter into HCP parameter family and set the following parameters.	
SEr	1	Machine arranged for remote connection to PC.
6. Switch OFF and then switch ON the machine.		
GE_n	Enter into GEn parameter family.	
dIn	165	Initial Detergent Dosage.
rIn	0	Initial Rinse Aid Dosage.
dEt	182	Detergent dispenser works when LOAD SOLENOID VALVE in activated.
rA_i	61	Rinse Aid dispenser works when LOAD SOLENOID VALVE in activated.
7. Switch OFF and then switch ON the machine.		

WARNING:

To set the board parameters , carefully follow the order given in this programming file, from point 1 to point 7.

WARNING:

When modifying parameter **dFL** , all the parameters (except those belonging to the **CFG** family) assume the default values according to the tables in section 11 DEFAULT VALUES. The parameters of the **CFG** family are not modified.



ZUCAI / AUCAIG / EUCAI / NUCAI

PROG 106

1. Switch OFF and then switch ON the machine.

2. **CFG** Enter into CFG parameter family and set the following parameters:

tYP	0	Hood Type and undercounter.
boi	0	Atmospheric boiler.
doo	2	Front loading function.
dFl	3	Default values for Undercounter models.
trc	1	SOFT START enabled.
b.t	1	Tank heater works only if boiler temperature reached.
b.tF	75	Enable filling tank by means of rinsing cycles.
LES	0	Detergent level switches not enabled.
U1	9	Select user interface hood type/ undercounter model.
rE	0	Regeneration cycle disabled.
Alr	1	Alarms enabled.
RAQ	0	Boiler electronic level sensor.
FrG	0	Resin regeneration cycle forcing.
SrU	10	Rinse water max. hardness.
bPo	50	Boiler heating control.

3. Switch OFF and then switch ON the machine.

4. Modify Factory parameters:

FAC Enter into FAC parameter family and set the following parameters.

b.tC	80	Boiler Temperature Threshold.
b.H1	96	Boiler temperature: alarm threshold.
b.AJ	0	Boiler Temperature Adjust.
b.P	1	Boiler standby function enabled.
b.St	2	Booster Function.
b.td	3	During stand-by boiler is kept at lower temperature than Temperature Threshold.
t.tC	63	Tub Temperature: Threshold.
t.H1	75	Tank temperature: alarm threshold.

5. Modify the cycle parameters:

CY1 Cycle 1 parameters family.

L.n1	1	Long Wash Phase [min].
S.h1	12	Short Wash Phase [s].
P.A1	4	Pause [s].
r.i1	12	Rinse Phase Duration [s].
d.r1	25	Drain [s].
F.P1	2	Final Pause [s].

CY2 Cycle 2 parameters family.

L.n2	1	Long Wash Phase [min].
S.h2	42	Short Wash Phase [s].
P.A2	4	Pause [s].
r.i2	12	Rinse Phase Duration [s].
d.r2	25	Drain [s].
F.P2	2	Final Pause [s].

CY3 Cycle 3 parameters family.

L.n3	3	Long Wash Phase [min].
S.h3	42	Short Wash Phase [s].
P.A3	4	Pause [s].
r.i3	12	Rinse Phase Duration [s].
d.r3	25	Drain [s].
F.P3	2	Final Pause [s].
b.t3	0	Boiler Temperature Threshold for Cycle 3.

**ZUCAI / AUCAIG / EUCAI /
NUCAI****PROG 106**

drn	Drain parameters family.		
ldr	30	Initial Drain Phase Duration [s].	
Fdr	80	Final Drain Phase Duration [s].	
drk	0	Drain and cleaning mode.	
cbd	0	Wash tank water change frequency control disabled.	
dPA	Set other parameters.		
IPA	0	Initial Pause [s] (for ALL cycles).	
dLY	3	Delay for the 2 nd wash pump [s].	
Pdr	0	Drain Phase Duration at the end of washing phase [s].	
rPA	0	Duration of pause after the rinse cycle [s] (for ALL cycles).	
CF	0	Degrees Celsius display.	
rit	0	During the rinse stage, the display shows the boiler temperature.	
tLE	0	Termal Label mode disabled (Functions present with firmware version 4.04).	
HCP	Enter into HCP parameter family and set the following parameters.		
SEr	1	Machine arranged for remote connection to PC.	
6. Switch OFF and then switch ON the machine.			
GE_n	Enter into GEn parameter family.		
dIn	50	Initial Detergent Dosage.	
rIn	10	Initial Rinse Aid Dosage.	
dEt	6	Detergent dispensing during the wash cycle (loading during wash stage).	
rA_i	4	Rinse aid dispensing during the rinse cycle (loading during boiler filling stage).	
7. Switch OFF and then switch ON the machine.			

WARNING:

To set the board parameters , carefully follow the order given in this programming file, from point 1 to point 7.

WARNING:

When modifying parameter **dFL**, all the parameters (except those belonging to the **CFE** family) assume the default values according to the tables in section 11 DEFAULT VALUES. The parameters of the **CFE** family are not modified.



ZUCAI / AUCAI / EUCAI / NUCAI WS

PROG 107

1. Switch OFF and then switch ON the machine.

2. **CFG** Enter into CFG parameter family and set the following parameters:

tYP	0	Hood Type and undercounter.
boi	0	Atmospheric boiler.
doo	2	Front loading function.
dFL	3	Default values for Undercounter models.
trc	1	SOFT START enabled.
b.t	1	Tank heater works only if boiler temperature reached.
b.tF	75	Enable filling tank by means of rinsing cycles.
LES	0	Detergent level switches not enabled.
UI	9	Select user interface hood type/ undercounter model.
rE	0	Regeneration cycle disabled (only for dishwashers with non-continuous water softener).
Alr	1	Alarms enabled.
RRG	1	Boiler float level sensor.
FrG	0	Resin regeneration cycle forcing.
SrU	10	Rinse water max. hardness.
bPo	50	Boiler heating control.

3. Switch OFF and then switch ON the machine.

4. Modify Factory parameters:

FAC Enter into FAC parameter family and set the following parameters.

b.tC	80	Boiler Temperature Threshold.
b.Hi	96	Boiler temperature: alarm threshold.
b.AJ	0	Boiler Temperature Adjust.
b.P	1	Boiler standby function enabled.
b.St	2	Booster Function.
b.td	3	During stand-by boiler is kept at lower temperature than Temperature Threshold.
t.tC	63	Tub Temperature: Threshold.
t.Hi	75	Tank temperature: alarm threshold.

5. Modify the cycle parameters:

CY1 Cycle 1 parameters family.

Ln1	1	Long Wash Phase [min].
Sh1	12	Short Wash Phase [s].
PA1	4	Pause [s].
r.i1	12	Rinse Phase Duration [s].
dr1	25	Drain [s].
FP1	2	Final Pause [s].

CY2 Cycle 2 parameters family.

Ln2	1	Long Wash Phase [min].
Sh2	42	Short Wash Phase [s].
PA2	4	Pause [s].
r.i2	12	Rinse Phase Duration [s].
dr2	25	Drain [s].
FP2	2	Final Pause [s].

CY3 Cycle 3 parameters family.

Ln3	3	Long Wash Phase [min].
Sh3	42	Short Wash Phase [s].
PA3	4	Pause [s].
r.i3	12	Rinse Phase Duration [s].
dr3	25	Drain [s].
FP3	2	Final Pause [s].
b.t3	0	Boiler Temperature Threshold for Cycle 3.

**ZUCAI / AUCAI / EUCAI /
NUCAI WS****PROG 107**

drn	Drain parameters family.		
idr	30	Initial Drain Phase Duration [s].	
Fdr	80	Final Drain Phase Duration [s].	
drk	0	Drain and cleaning mode.	
cbd	0	Wash tank water change frequency control disabled.	
dPA	Set other parameters.		
IPR	0	Initial Pause [s] (for ALL cycles).	
dLY	3	Delay for the 2 nd wash pump [s].	
Pdr	0	Drain Phase Duration at the end of washing phase [s].	
rPA	0	Duration of pause after the rinse cycle [s] (for ALL cycles).	
CF	0	Degrees Celsius display.	
rit	0	During the rinse stage, the display shows the boiler temperature.	
HCP	Enter into HCP parameter family and set the following parameters.		
SEr	9	Dishwasher with incorporated continuous water softener.	
6. Switch OFF and then switch ON the machine.			
GEr	Enter into GEn parameter family.		
dIn	50	Initial Detergent Dosage.	
rIn	10	Initial Rinse Aid Dosage.	
dEt	6	Detergent dispensing during the wash cycle (loading during wash stage).	
rA, 	4	Rinse aid dispensing during the rinse cycle (loading during boiler filling stage).	
7. Switch OFF and then switch ON the machine.			

WARNING:

To set the board parameters , carefully follow the order given in this programming file, from point 1 to point 7.

WARNING:

When modifying parameter *dFL* , all the parameters (except those belonging to the *CFG* family) assume the default values according to the tables in section 11 DEFAULT VALUES. The parameters of the *CFG* family are not modified.

**EUCAIML****PROG 108**

1. Switch OFF and then switch ON the machine.

2. **CFG** Enter into CFG parameter family and set the following parameters:

LYP	0	Hood Type and undercounter.
bo1	0	Atmospheric boiler.
dao	2	Front loading function.
dFL	3	Default values for Undercounter models.
trc	1	SOFT START enabled.
b.t	1	Tank heater works only if boiler temperature reached.
btf	75	Enable filling tank by means of rinsing cycles.
LES	0	Detergent level switches not enabled.
U1	0	ACTIVE function disabled.
rE	0	Regeneration cycle disabled (only for dishwashers with non-continuous water softener).
Alr	1	Alarms enabled.
AAE	0	Boiler electronic level sensor.
FrG	0	Resin regeneration cycle forcing.
SrU	10	Rinse water max. hardness.
bPo	50	Boiler heating control.

3. Switch OFF and then switch ON the machine.

4. Modify Factory parameters:

FAC Enter into FAC parameter family and set the following parameters.

bte	90	Boiler Temperature Threshold.
bH1	0	Disable boiler high Temperature alarm (1 2).
BAJ	0	Boiler Temperature Adjust.
bP	1	Boiler standby function enabled.
bSt	0	Booster Function.
btd	10	During stand-by boiler is kept at lower temperature than Temperature Threshold.
ttE	65	Tub Temperature: Threshold.
tH1	85	Tank temperature: alarm threshold.

5. Modify the cycle parameters:

CY1 Cycle 1 parameters family.

Ln1	4	Long Wash Phase [min].
Sh1	10	Short Wash Phase [s].
PA1	4	Pause [s].
r11	35	Rinse Phase Duration [s].
dr1	40	Drain [s].
FP1	15	Final Pause [s].

CY2 Cycle 2 parameters family.

Ln2	6	Long Wash Phase [min].
Sh2	10	Short Wash Phase [s].
PA2	4	Pause [s].
r12	35	Rinse Phase Duration [s].
dr2	40	Drain [s].
FP2	15	Final Pause [s].

CY3 Cycle 3 parameters family.

Ln3	9	Long Wash Phase [min].
Sh3	10	Short Wash Phase [s].
PA3	4	Pause [s].
r13	35	Rinse Phase Duration [s].
dr3	40	Drain [s].
FP3	15	Final Pause [s].
bte3	0	Boiler Temperature Threshold for Cycle 3.

**EUCAIML****PROG 108**

drn	Drain parameters family.		
idr	30	Initial Drain Phase Duration [s].	
fdr	80	Final Drain Phase Duration [s].	
drt	0	Drain and cleaning mode.	
cbd	0	Wash tank water change frequency control disabled.	
dPA	Set other parameters.		
ipa	0	Initial Pause [s] (for ALL cycles).	
dly	3	Delay for the 2 nd wash pump [s].	
pdr	0	Drain Phase Duration at the end of washing phase [s].	
rPA	0	Duration of pause after the rinse cycle [s] (for ALL cycles).	
CF	0	Degrees Celsius display.	
rit	0	During the rinse stage, the display shows the boiler temperature.	
HCP	Enter into HCP parameter family and set the following parameters.		
SEr	1	Machine arranged for remote connection to PC.	
6. Switch OFF and then switch ON the machine.			
GE_n	Enter into GEn parameter family.		
dIn	50	Initial Detergent Dosage.	
rIn	10	Initial Rinse Aid Dosage.	
dEt	8	Detergent dispensing during the wash cycle (loading during wash stage).	
rA_i	4	Rinse aid dispensing during the rinse cycle (loading during boiler filling stage).	
7. Switch OFF and then switch ON the machine.			

WARNING:

To set the board parameters , carefully follow the order given in this programming file, from point 1 to point 7.

WARNING:

When modifying parameter **dFL** , all the parameters (except those belonging to the **CFG** family) assume the default values according to the tables in section 11 DEFAULT VALUES. The parameters of the **CFG** family are not modified.

**EUCAIMLWS****PROG 109**

1. Switch OFF and then switch ON the machine.		
2.	CFG	Enter into CFG parameter family and set the following parameters:
	tYP	0 Hood Type and undercounter.
	bo i	0 Atmospheric boiler.
	dao	2 Front loading function.
	dFl	3 Default values for Undercounter models.
	trc	1 SOFT START enabled.
	b_t	1 Tank heater works only if boiler temperature reached.
	btF	75 Enable filling tank by means of rinsing cycles.
	LES	0 Detergent level switches not enabled.
	U1	0 ACTIVE function disabled.
	rE	0 Regeneration cycle disabled (only for dishwashers with non-continuous water softener).
	Al r	1 Alarms enabled.
	AAc	1 Boiler float level sensor.
	FrC	0 Resin regeneration cycle forcing.
	SrU	10 Rinse water max. hardness.
	bPo	50 Boiler heating control.
3. Switch OFF and then switch ON the machine.		
4. Modify Factory parameters:		
	FAC	Enter into FAC parameter family and set the following parameters.
	btC	90 Boiler Temperature Threshold.
	bH i	0 Disable boiler high Temperature alarm (1 2).
	BAJ	0 Boiler Temperature Adjust.
	bP	1 Boiler standby function enabled.
	bSt	0 Booster Function.
	bt d	10 During stand-by boiler is kept at lower temperature than Temperature Threshold.
	ttC	65 Tub Temperature: Threshold.
	tH i	85 Tank temperature: alarm threshold.
5. Modify the cycle parameters:		
	CY1	Cycle 1 parameters family.
	Ln1	4 Long Wash Phase [min].
	Sh1	10 Short Wash Phase [s].
	PA1	4 Pause [s].
	r i1	35 Rinse Phase Duration [s].
	dr1	40 Drain [s].
	FP1	15 Final Pause [s].
	CY2	Cycle 2 parameters family.
	Ln2	6 Long Wash Phase [min].
	Sh2	10 Short Wash Phase [s].
	PA2	4 Pause [s].
	r i2	35 Rinse Phase Duration [s].
	dr2	40 Drain [s].
	FP2	15 Final Pause [s].
	CY3	Cycle 3 parameters family.
	Ln3	9 Long Wash Phase [min].
	Sh3	10 Short Wash Phase [s].
	PA3	4 Pause [s].
	r i3	35 Rinse Phase Duration [s].
	dr3	40 Drain [s].
	FP3	15 Final Pause [s].
	bt3	0 Boiler Temperature Threshold for Cycle 3.

**EUCAIMLWS****PROG 109**

drn	Drain parameters family.		
idr	30	Initial Drain Phase Duration [s].	
fdr	80	Final Drain Phase Duration [s].	
drt	0	Drain and cleaning mode.	
cbd	0	Wash tank water change frequency control disabled.	
dPA	Set other parameters.		
ipa	0	Initial Pause [s] (for ALL cycles).	
dly	3	Delay for the 2 nd wash pump [s].	
pdr	0	Drain Phase Duration at the end of washing phase [s].	
rPA	0	Duration of pause after the rinse cycle [s] (for ALL cycles).	
CF	0	Degrees Celsius display.	
rit	0	During the rinse stage, the display shows the boiler temperature.	
HCP	Enter into HCP parameter family and set the following parameters.		
SEr	9	Dishwasher with incorporated continuous water softener.	
6. Switch OFF and then switch ON the machine.			
GEN	Enter into GEN parameter family.		
dIn	50	Initial Detergent Dosage.	
rIn	10	Initial Rinse Aid Dosage.	
dEt	8	Detergent dispensing during the wash cycle (loading during wash stage).	
rA_i	4	Rinse aid dispensing during the rinse cycle (loading during boiler filling stage).	
7. Switch OFF and then switch ON the machine.			

WARNING:

To set the board parameters , carefully follow the order given in this programming file, from point 1 to point 7.

WARNING:

When modifying parameter **dFL** , all the parameters (except those belonging to the **CFG** family) assume the default values according to the tables in section 11 DEFAULT VALUES. The parameters of the **CFG** family are not modified.



EUCAIMLG

PROG 110

1. Switch OFF and then switch ON the machine.

2. **CFG** Enter into CFG parameter family and set the following parameters:

LYP	3	Medical line dishwasher with lock door/hood device.
bo1	0	Atmospheric boiler.
dao	2	Front loading function.
dFl	3	Default values for Undercounter models.
trc	1	SOFT START enabled.
b.t	1	Tank heater works only if boiler temperature reached.
btf	75	Enable filling tank by means of rinsing cycles.
LES	0	Detergent level switches not enabled.
U1	0	ACTIVE function disabled.
rE	0	Regeneration cycle disabled (only for dishwashers with non-continuous water softener).
Alr	1	Alarms enabled.
AAE	0	Boiler electronic level sensor.
FrG	0	Resin regeneration cycle forcing.
SrU	10	Rinse water max. hardness.
bPo	50	Boiler heating control.

3. Switch OFF and then switch ON the machine.

4. Modify Factory parameters:

FAC Enter into FAC parameter family and set the following parameters.

bte	92	Boiler Temperature Threshold.
bH1	0	Disable boiler high Temperature alarm (1 2).
BAJ	0	Boiler Temperature Adjust.
bP	1	Boiler standby function enabled.
bSt	0	Booster Function.
btd	10	During stand-by boiler is kept at lower temperature than Temperature Threshold.
te	65	Tub Temperature: Threshold.
tH1	85	Tank temperature: alarm threshold.

5. Modify the cycle parameters:

Y1 Cycle 1 parameters family.

Ln1	3	Long Wash Phase [min].
Sh1	35	Short Wash Phase [s].
PA1	5	Pause [s].
r1	35	Rinse Phase Duration [s].
dr1	40	Drain [s].
FP1	60	Final Pause [s].

Y2 Cycle 2 parameters family.

Ln2	6	Long Wash Phase [min].
Sh2	35	Short Wash Phase [s].
PA2	5	Pause [s].
r2	35	Rinse Phase Duration [s].
dr2	40	Drain [s].
FP2	60	Final Pause [s].

Y3 Cycle 3 parameters family.

Ln3	8	Long Wash Phase [min].
Sh3	35	Short Wash Phase [s].
PA3	5	Pause [s].
r3	35	Rinse Phase Duration [s].
dr3	40	Drain [s].
FP3	60	Final Pause [s].
bte3	0	Boiler Temperature Threshold for Cycle 3.

**EUCAIMLG****PROG 110**

drn	Drain parameters family.		
idr	30	Initial Drain Phase Duration [s].	
fdr	80	Final Drain Phase Duration [s].	
drt	0	Drain and cleaning mode.	
cbd	0	Wash tank water change frequency control disabled.	
dPA	Set other parameters.		
ipa	0	Initial Pause [s] (for ALL cycles).	
dly	3	Delay for the 2 nd wash pump [s].	
pdr	0	Drain Phase Duration at the end of washing phase [s].	
rPA	45	Duration of pause after the rinse cycle [s] (for ALL cycles).	
CF	0	Degrees Celsius display.	
rit	0	During the rinse stage, the display shows the boiler temperature.	
HCP	Enter into HCP parameter family and set the following parameters.		
SEr	1	Machine arranged for remote connection to PC.	
6. Switch OFF and then switch ON the machine.			
GEN	Enter into GEN parameter family.		
dIn	50	Initial Detergent Dosage.	
rIn	10	Initial Rinse Aid Dosage.	
dEt	8	Detergent dispensing during the wash cycle (loading during wash stage).	
rA_i	4	Rinse aid dispensing during the rinse cycle (loading during boiler filling stage).	
7. Switch OFF and then switch ON the machine.			

WARNING:

To set the board parameters , carefully follow the order given in this programming file, from point 1 to point 7.

WARNING:

When modifying parameter *dFL* , all the parameters (except those belonging to the *CFG* family) assume the default values according to the tables in section 11 DEFAULT VALUES. The parameters of the *CFG* family are not modified.



EUCAICL

PROG 111

1. Switch OFF and then switch ON the machine.

2. **CFG** Enter into CFG parameter family and set the following parameters:

LYP	0	Hood Type and undercounter.
bo1	0	Atmospheric boiler.
dao	2	Front loading function.
dFL	3	Default values for Undercounter models.
trc	1	SOFT START enabled.
b.t	1	Tank heater works only if boiler temperature reached.
btF	75	Enable filling tank by means of rinsing cycles.
LES	1	Detergent level switches enabled.
U1	9	Select user interface hood type/ undercounter model.
rE	0	Regeneration cycle disabled (only for dishwashers with non-continuous water softener).
Alr	1	Alarms enabled.
AAE	0	Boiler electronic level sensor.
FrE	0	Resin regeneration cycle forcing.
SrU	10	Rinse water max. hardness.
bPo	50	Boiler heating control.

3. Switch OFF and then switch ON the machine.

4. Modify Factory parameters:

FAC Enter into FAC parameter family and set the following parameters.

btE	80	Boiler Temperature Threshold.
bH1	96	Boiler temperature: alarm threshold.
BAJ	0	Boiler Temperature Adjust.
bP	1	Boiler standby function enabled.
bSt	2	Booster Function.
btD	3	During stand-by boiler is kept at lower temperature than Temperature Threshold.
ttE	63	Tub Temperature: Threshold.
tH1	75	Tank temperature: alarm threshold.

5. Modify the cycle parameters:

Y1 Cycle 1 parameters family.

Ln1	1	Long Wash Phase [min].
Sh1	12	Short Wash Phase [s].
PA1	4	Pause [s].
r11	12	Rinse Phase Duration [s].
dr1	25	Drain [s].
FP1	2	Final Pause [s].

Y2 Cycle 2 parameters family.

Ln2	1	Long Wash Phase [min].
Sh2	42	Short Wash Phase [s].
PA2	4	Pause [s].
r12	12	Rinse Phase Duration [s].
dr2	25	Drain [s].
FP2	2	Final Pause [s].

Y3 Cycle 3 parameters family.

Ln3	3	Long Wash Phase [min].
Sh3	42	Short Wash Phase [s].
PA3	4	Pause [s].
r13	12	Rinse Phase Duration [s].
dr3	25	Drain [s].
FP3	2	Final Pause [s].
bt3	0	Boiler Temperature Threshold for Cycle 3.

**EUCAICL****PROG 111**

drn	Drain parameters family.		
idr	30	Initial Drain Phase Duration [s].	
fdr	80	Final Drain Phase Duration [s].	
drt	0	Drain and cleaning mode.	
lbd	0	Wash tank water change frequency control disabled.	
dPA	Set other parameters.		
ipa	0	Initial Pause [s] (for ALL cycles).	
dly	3	Delay for the 2 nd wash pump [s].	
pdr	0	Drain Phase Duration at the end of washing phase [s].	
rPA	0	Duration of pause after the rinse cycle [s] (for ALL cycles).	
CF	0	Degrees Celsius display.	
rit	0	During the rinse stage, the display shows the boiler temperature.	
HCP	Enter into HCP parameter family and set the following parameters.		
SEr	1	Machine arranged for remote connection to PC.	
6. Switch OFF and then switch ON the machine.			
GEr	Enter into GEn parameter family.		
dIn	50	Initial Detergent Dosage.	
rIn	10	Initial Rinse Aid Dosage.	
dEt	6	Detergent dispensing during the wash cycle (loading during wash stage).	
rA_i	4	Rinse aid dispensing during the rinse cycle (loading during boiler filling stage).	
7. Switch OFF and then switch ON the machine.			

WARNING:

To set the board parameters , carefully follow the order given in this programming file, from point 1 to point 7.

WARNING:

When modifying parameter *dFL* , all the parameters (except those belonging to the *CFG* family) assume the default values according to the tables in section 11 DEFAULT VALUES. The parameters of the *CFG* family are not modified.



EUCAIWL

PROG 112

1. Switch OFF and then switch ON the machine.

2. **CFG** Enter into CFG parameter family and set the following parameters:

LYP	0	Hood Type and undercounter.
bo1	0	Atmospheric boiler.
dao	2	Front loading function.
dFL	3	Default values for Undercounter models.
trc	1	SOFT START enabled.
b.t	1	Tank heater works only if boiler temperature reached.
btf	65	Enable filling tank by means of rinsing cycles.
LES	0	Detergent level switches not enabled.
U1	9	Select user interface hood type/ undercounter model.
rE	0	Regeneration cycle disabled (only for dishwashers with non-continuous water softener).
Alr	1	Alarms enabled.
RAE	0	Boiler electronic level sensor.
FrG	0	Resin regeneration cycle forcing.
SrU	10	Rinse water max. hardness.
bPo	50	Boiler heating control.

3. Switch OFF and then switch ON the machine.

4. Modify Factory parameters:

FAC Enter into FAC parameter family and set the following parameters.

bTt	80	Boiler Temperature Threshold.
bH1	96	Boiler temperature: alarm threshold.
BAJ	0	Boiler Temperature Adjust.
bP	1	Boiler standby function enabled.
bSt	2	Booster Function.
btd	3	During stand-by boiler is kept at lower temperature than Temperature Threshold.
tTt	55	Tub Temperature: Threshold.
tH1	75	Tank temperature: alarm threshold.

5. Modify the cycle parameters:

Y1 Cycle 1 parameters family.

Ln1	1	Long Wash Phase [min].
Sh1	12	Short Wash Phase [s].
PA1	4	Pause [s].
r11	12	Rinse Phase Duration [s].
dr1	25	Drain [s].
FP1	2	Final Pause [s].

Y2 Cycle 2 parameters family.

Ln2	1	Long Wash Phase [min].
Sh2	35	Short Wash Phase [s].
PA2	4	Pause [s].
r12	12	Rinse Phase Duration [s].
dr2	25	Drain [s].
FP2	2	Final Pause [s].

Y3 Cycle 3 parameters family.

Ln3	2	Long Wash Phase [min].
Sh3	35	Short Wash Phase [s].
PA3	4	Pause [s].
r13	12	Rinse Phase Duration [s].
dr3	25	Drain [s].
FP3	2	Final Pause [s].
bT3	0	Boiler Temperature Threshold for Cycle 3.

**EUCAIWL****PROG 112**

drn	Drain parameters family.		
idr	30	Initial Drain Phase Duration [s].	
fdr	80	Final Drain Phase Duration [s].	
drt	0	Drain and cleaning mode.	
cbd	0	Wash tank water change frequency control disabled.	
dPA	Set other parameters.		
ipa	0	Initial Pause [s] (for ALL cycles).	
dly	3	Delay for the 2 nd wash pump [s].	
pdr	0	Drain Phase Duration at the end of washing phase [s].	
rPA	0	Duration of pause after the rinse cycle [s] (for ALL cycles).	
CF	0	Degrees Celsius display.	
rit	0	During the rinse stage, the display shows the boiler temperature.	
HCP	Enter into HCP parameter family and set the following parameters.		
SEr	1	Machine arranged for remote connection to PC.	
6. Switch OFF and then switch ON the machine.			
GE_n	Enter into GEn parameter family.		
dIn	25	Initial Detergent Dosage.	
rIn	10	Initial Rinse Aid Dosage.	
dEt	4	Detergent dispensing during the wash cycle (loading during wash stage).	
rA_i	4	Rinse aid dispensing during the rinse cycle (loading during boiler filling stage).	
7. Switch OFF and then switch ON the machine.			

WARNING:

To set the board parameters , carefully follow the order given in this programming file, from point 1 to point 7.

WARNING:

When modifying parameter *dFL* , all the parameters (except those belonging to the *CFG* family) assume the default values according to the tables in section 11 DEFAULT VALUES. The parameters of the *CFG* family are not modified.



EUCAICLW

PROG 113

1. Switch OFF and then switch ON the machine.

2. **CFG** Enter into CFG parameter family and set the following parameters:

LYP	0	Hood Type and undercounter.
bo1	0	Atmospheric boiler.
dao	2	Front loading function.
dFL	3	Default values for Undercounter models.
trc	1	SOFT START enabled.
b.t	1	Tank heater works only if boiler temperature reached.
btF	75	Enable filling tank by means of rinsing cycles.
LES	1	Detergent level switches enabled.
U1	9	Select user interface hood type/ undercounter model.
rE	0	Regeneration cycle disabled (only for dishwashers with non-continuous water softener).
Alr	1	Alarms enabled.
RAE	0	Boiler electronic level sensor.
FrG	0	Resin regeneration cycle forcing.
SrU	10	Rinse water max. hardness.
bPo	50	Boiler heating control.

3. Switch OFF and then switch ON the machine.

4. Modify Factory parameters:

FAC Enter into FAC parameter family and set the following parameters.

btT	70	Boiler Temperature Threshold.
bH1	96	Boiler temperature: alarm threshold.
BAJ	4	Boiler Temperature Adjust.
bP	1	Boiler standby function enabled.
bSt	2	Booster Function.
btD	0	During stand-by boiler is kept at lower temperature than Temperature Threshold.
tT	63	Tub Temperature: Threshold.
tH1	75	Tank temperature: alarm threshold.

5. Modify the cycle parameters:

Y1 Cycle 1 parameters family.

Ln1	1	Long Wash Phase [min].
Sh1	12	Short Wash Phase [s].
PA1	4	Pause [s].
r1	12	Rinse Phase Duration [s].
dr1	25	Drain [s].
FP1	2	Final Pause [s].

Y2 Cycle 2 parameters family.

Ln2	1	Long Wash Phase [min].
Sh2	42	Short Wash Phase [s].
PA2	4	Pause [s].
r2	12	Rinse Phase Duration [s].
dr2	25	Drain [s].
FP2	2	Final Pause [s].

Y3 Cycle 3 parameters family.

Ln3	3	Long Wash Phase [min].
Sh3	42	Short Wash Phase [s].
PA3	4	Pause [s].
r3	12	Rinse Phase Duration [s].
dr3	25	Drain [s].
FP3	2	Final Pause [s].
bt3	0	Boiler Temperature Threshold for Cycle 3.

**EUCAICLW****PROG 113**

drn	Drain parameters family.		
idr	30	Initial Drain Phase Duration [s].	
fdr	80	Final Drain Phase Duration [s].	
drt	1	Drain and cleaning mode.	
cbd	0	Wash tank water change frequency control disabled.	
dPA	Set other parameters.		
ipa	0	Initial Pause [s] (for ALL cycles).	
dly	3	Delay for the 2 nd wash pump [s].	
pdr	0	Drain Phase Duration at the end of washing phase [s].	
rPA	0	Duration of pause after the rinse cycle [s] (for ALL cycles).	
CF	0	Degrees Celsius display.	
rit	0	During the rinse stage, the display shows the boiler temperature.	
HCP	Enter into HCP parameter family and set the following parameters.		
SEr	1	Machine arranged for remote connection to PC.	
6. Switch OFF and then switch ON the machine.			
GEr	Enter into GEn parameter family.		
dIn	90	Initial Detergent Dosage.	
rIn	10	Initial Rinse Aid Dosage.	
dEt	6	Detergent dispensing during the wash cycle (loading during wash stage).	
rA,	4	Rinse aid dispensing during the rinse cycle (loading during boiler filling stage).	
7. Switch OFF and then switch ON the machine.			

WARNING:

To set the board parameters , carefully follow the order given in this programming file, from point 1 to point 7.

WARNING:

When modifying parameter *dFL* , all the parameters (except those belonging to the *CFG* family) assume the default values according to the tables in section 11 DEFAULT VALUES. The parameters of the *CFG* family are not modified.



ZUCI / AUCI / EUCI

PROG 114

1. Switch OFF and then switch ON the machine.

2. **CFG** Enter into CFG parameter family and set the following parameters:

LYP	0	Hood Type and undercounter.
bo1	1	Pressure boiler.
dao	2	Front loading function.
dFL	3	Default values for Undercounter models.
trc	1	SOFT START enabled.
b.t	1	Tank heater works only if boiler temperature reached.
btf	0	The tank is filled into the traditional way.
LES	0	Detergent level switches not enabled.
U1	0	ACTIVE function disabled.
rE	0	Regeneration cycle disabled (only for dishwashers with non-continuous water softener).
Alr	1	Alarms enabled.
RAE	0	Boiler electronic level sensor.
FrG	0	Resin regeneration cycle forcing.
SrU	10	Rinse water max. hardness.
bPo	50	Boiler heating control.

3. Switch OFF and then switch ON the machine.

4. Modify Factory parameters:

FAC Enter into FAC parameter family and set the following parameters.

bTt	86	Boiler Temperature Threshold.
bH1	96	Boiler temperature: alarm threshold.
BAJ	0	Boiler Temperature Adjust.
bP	1	Boiler standby function enabled.
bSt	2	Booster Function.
btd	3	During stand-by boiler is kept at lower temperature than Temperature Threshold.
tTt	63	Tub Temperature: Threshold.
tH1	75	Tank temperature: alarm threshold.

5. Modify the cycle parameters:

CY1 Cycle 1 parameters family.

Ln1	1	Long Wash Phase [min].
Sh1	10	Short Wash Phase [s].
PA1	4	Pause [s].
r11	16	Rinse Phase Duration [s].
dr1	30	Drain [s].
FP1	0	Final Pause [s].

CY2 Cycle 2 parameters family.

Ln2	1	Long Wash Phase [min].
Sh2	40	Short Wash Phase [s].
PA2	4	Pause [s].
r12	16	Rinse Phase Duration [s].
dr2	30	Drain [s].
FP2	0	Final Pause [s].

CY3 Cycle 3 parameters family.

Ln3	3	Long Wash Phase [min].
Sh3	40	Short Wash Phase [s].
PA3	4	Pause [s].
r13	16	Rinse Phase Duration [s].
dr3	30	Drain [s].
FP3	0	Final Pause [s].
bTt3	0	Boiler Temperature Threshold for Cycle 3.

**ZUCI / AUCI / EUCI****PROG 114**

drn	Drain parameters family.		
idr	30	Initial Drain Phase Duration [s].	
fdr	80	Final Drain Phase Duration [s].	
drt	0	Drain and cleaning mode.	
cbd	0	Wash tank water change frequency control disabled.	
dPA	Set other parameters.		
ipa	0	Initial Pause [s] (for ALL cycles).	
dly	3	Delay for the 2 nd wash pump [s].	
pdr	0	Drain Phase Duration at the end of washing phase [s].	
rPA	0	Duration of pause after the rinse cycle [s] (for ALL cycles).	
CF	0	Degrees Celsius display.	
rit	0	During the rinse stage, the display shows the boiler temperature.	
HCP	Enter into HCP parameter family and set the following parameters.		
SEr	1	Machine arranged for remote connection to PC.	
6. Switch OFF and then switch ON the machine.			
GE_n	Enter into GEn parameter family.		
dIn	50	Initial Detergent Dosage.	
rIn	10	Initial Rinse Aid Dosage.	
dEt	8	Detergent dispensing during the wash cycle (loading during wash stage).	
rA_i	4	Rinse aid dispensing during the rinse cycle (loading during boiler filling stage).	
7. Switch OFF and then switch ON the machine.			

WARNING:

To set the board parameters , carefully follow the order given in this programming file, from point 1 to point 7.

WARNING:

When modifying parameter **dFL** , all the parameters (except those belonging to the **CFG** family) assume the default values according to the tables in section 11 DEFAULT VALUES. The parameters of the **CFG** family are not modified.



EUCIM

PROG 115

1. Switch OFF and then switch ON the machine.

2. **CFG** Enter into CFG parameter family and set the following parameters:

LYP	0	Hood Type and undercounter.
boi	1	Pressure boiler.
dao	2	Front loading function.
dFl	3	Default values for Undercounter models.
trc	0	Disabled (for this appliance SOFT START is NOT possible).
b_t	1	Tank heater works only if boiler temperature reached.
btf	75	Enable filling tank by means of rinsing cycles.
LES	0	Detergent level switches not enabled.
U1	9	Select user interface hood type/ undercounter model.
rE	0	Regeneration cycle disabled (only for dishwashers with non-continuous water softener).
Alr	1	Alarms enabled.
AAE	0	Boiler electronic level sensor.
FrG	0	Resin regeneration cycle forcing.
SrU	10	Rinse water max. hardness.
bPo	50	Boiler heating control.

3. Switch OFF and then switch ON the machine.

4. Modify Factory parameters:

FAC Enter into FAC parameter family and set the following parameters.

bTt	90	Boiler Temperature Threshold.
bH1	0	Disable boiler high Temperature alarm (1 2).
BAJ	0	Boiler Temperature Adjust.
bP	1	Boiler standby function enabled.
bSt	2	Booster Function.
btd	10	During stand-by boiler is kept at lower temperature than Temperature Threshold.
tTt	66	Tub Temperature: Threshold.
tH1	85	Tank temperature: alarm threshold.

5. Modify the cycle parameters:

CY1 Cycle 1 parameters family.

Ln1	1	Long Wash Phase [min].
Sh1	10	Short Wash Phase [s].
PA1	4	Pause [s].
ri1	16	Rinse Phase Duration [s].
dr1	30	Drain [s].
FP1	0	Final Pause [s].

CY2 Cycle 2 parameters family.

Ln2	1	Long Wash Phase [min].
Sh2	40	Short Wash Phase [s].
PA2	4	Pause [s].
ri2	16	Rinse Phase Duration [s].
dr2	30	Drain [s].
FP2	0	Final Pause [s].

CY3 Cycle 3 parameters family.

Ln3	3	Long Wash Phase [min].
Sh3	40	Short Wash Phase [s].
PA3	4	Pause [s].
ri3	16	Rinse Phase Duration [s].
dr3	30	Drain [s].
FP3	0	Final Pause [s].
bTt3	0	Boiler Temperature Threshold for Cycle 3.

**EUCIM****PROG 115**

drn	Drain parameters family.		
idr	30	Initial Drain Phase Duration [s].	
fdr	00	Final Drain Phase Duration [s].	
drt	0	Drain and cleaning mode.	
lbd	0	Wash tank water change frequency control disabled.	
dPA	Set other parameters.		
ipa	5	Initial Pause [s] (for ALL cycles).	
dly	3	Delay for the 2 nd wash pump [s].	
pdr	0	Drain Phase Duration at the end of washing phase [s].	
rPA	0	Duration of pause after the rinse cycle [s] (for ALL cycles).	
CF	0	Degrees Celsius display.	
rit	0	During the rinse stage, the display shows the boiler temperature.	
HCP	Enter into HCP parameter family and set the following parameters.		
SEr	1	Machine arranged for remote connection to PC.	
6. Switch OFF and then switch ON the machine.			
GE_n	Enter into GEn parameter family.		
dIn	50	Initial Detergent Dosage.	
rIn	10	Initial Rinse Aid Dosage.	
dEt	8	Detergent dispensing during the wash cycle (loading during wash stage).	
rA_i	4	Rinse aid dispensing during the rinse cycle (loading during boiler filling stage).	
7. Switch OFF and then switch ON the machine.			

WARNING:

To set the board parameters , carefully follow the order given in this programming file, from point 1 to point 7.

WARNING:

When modifying parameter **dFL** , all the parameters (except those belonging to the **CFG** family) assume the default values according to the tables in section 11 DEFAULT VALUES. The parameters of the **CFG** family are not modified.

**AUCAI****PROG 116**

1. Switch OFF and then switch ON the machine.

2. **CFG** Enter into CFG parameter family and set the following parameters:

LYP	0	Hood Type and undercounter.
bo1	0	Atmospheric boiler.
dao	2	Front loading function.
dFL	3	Default values for Undercounter models.
trc	1	SOFT START enabled.
b.t	1	Tank heater works only if boiler temperature reached.
btf	75	Enable filling tank by means of rinsing cycles.
LES	0	Detergent level switches not enabled.
U1	0	ACTIVE function disabled.
rE	0	Regeneration cycle disabled (only for dishwashers with non-continuous water softener).
Alr	1	Alarms enabled.
RAE	0	Boiler electronic level sensor.
FrG	0	Resin regeneration cycle forcing.
SrU	10	Rinse water max. hardness.
bPo	50	Boiler heating control.

3. Switch OFF and then switch ON the machine.

4. Modify Factory parameters:

FAC Enter into FAC parameter family and set the following parameters.

bTt	80	Boiler Temperature Threshold.
bH1	96	Boiler temperature: alarm threshold.
BAJ	0	Boiler Temperature Adjust.
bP	1	Boiler standby function enabled.
bSt	2	Booster Function.
btd	3	During stand-by boiler is kept at lower temperature than Temperature Threshold.
tTt	63	Tub Temperature: Threshold.
tH1	75	Tank temperature: alarm threshold.

5. Modify the cycle parameters:

Y1 Cycle 1 parameters family.

Ln1	1	Long Wash Phase [min].
Sh1	12	Short Wash Phase [s].
PA1	4	Pause [s].
r11	12	Rinse Phase Duration [s].
dr1	25	Drain [s].
FP1	2	Final Pause [s].

Y2 Cycle 2 parameters family.

Ln2	1	Long Wash Phase [min].
Sh2	42	Short Wash Phase [s].
PA2	4	Pause [s].
r12	12	Rinse Phase Duration [s].
dr2	25	Drain [s].
FP2	2	Final Pause [s].

Y3 Cycle 3 parameters family.

Ln3	3	Long Wash Phase [min].
Sh3	42	Short Wash Phase [s].
PA3	4	Pause [s].
r13	12	Rinse Phase Duration [s].
dr3	25	Drain [s].
FP3	2	Final Pause [s].
bTt3	0	Boiler Temperature Threshold for Cycle 3.

**AUCAI****PROG 116**

drn	Drain parameters family.		
idr	30	Initial Drain Phase Duration [s].	
fdr	80	Final Drain Phase Duration [s].	
drt	0	Drain and cleaning mode.	
cbd	0	Wash tank water change frequency control disabled.	
dPA	Set other parameters.		
ipa	0	Initial Pause [s] (for ALL cycles).	
dly	3	Delay for the 2 nd wash pump [s].	
pdr	0	Drain Phase Duration at the end of washing phase [s].	
rPA	0	Duration of pause after the rinse cycle [s] (for ALL cycles).	
CF	0	Degrees Celsius display.	
rit	0	During the rinse stage, the display shows the boiler temperature.	
HCP	Enter into HCP parameter family and set the following parameters.		
SEr	1	Machine arranged for remote connection to PC.	
6. Switch OFF and then switch ON the machine.			
GE_n	Enter into GEn parameter family.		
dIn	50	Initial Detergent Dosage.	
rIn	10	Initial Rinse Aid Dosage.	
dEt	6	Detergent dispensing during the wash cycle (loading during wash stage).	
rA_i	4	Rinse aid dispensing during the rinse cycle (loading during boiler filling stage).	
7. Switch OFF and then switch ON the machine.			

WARNING:

To set the board parameters , carefully follow the order given in this programming file, from point 1 to point 7.

WARNING:

When modifying parameter **dFL** , all the parameters (except those belonging to the **CFG** family) assume the default values according to the tables in section 11 DEFAULT VALUES. The parameters of the **CFG** family are not modified.



AUCAIDPWS		PROG 117	
1. Switch OFF and then switch ON the machine.			
2. CFG Enter into CFG parameter family and set the following parameters:			
	tYP	0	Hood Type and undercounter.
	bo i	0	Atmospheric boiler.
	dao	2	Front loading function.
	dFl	3	Default values for Undercounter models.
	trc	1	SOFT START enabled.
	b_t	1	Tank heater works only if boiler temperature reached.
	btF	75	Enable filling tank by means of rinsing cycles.
	LES	0	Detergent level switches not enabled.
	U i	9	Select user interface hood type/ undercounter model.
	rE	0	Regeneration cycle disabled (only for dishwashers with non-continuous water softener).
	Al r	1	Alarms enabled.
	AAc	1	Boiler float level sensor.
	FrC	0	Resin regeneration cycle forcing.
	SrU	10	Rinse water max. hardness.
	bPo	50	Boiler heating control.
3. Switch OFF and then switch ON the machine.			
4. Modify Factory parameters:			
FAC Enter into FAC parameter family and set the following parameters.			
	btC	80	Boiler Temperature Threshold.
	bH i	96	Boiler temperature: alarm threshold.
	BAJ	0	Boiler Temperature Adjust.
	bP	1	Boiler standby function enabled.
	bSt	2	Booster Function.
	bt d	3	During stand-by boiler is kept at lower temperature than Temperature Threshold.
	tC	63	Tub Temperature: Threshold.
	tH i	75	Tank temperature: alarm threshold.
5. Modify the cycle parameters:			
CY1 Cycle 1 parameters family.			
	Ln1	1	Long Wash Phase [min].
	Sh1	12	Short Wash Phase [s].
	PA1	4	Pause [s].
	r i1	12	Rinse Phase Duration [s].
	dr1	25	Drain [s].
	FP1	2	Final Pause [s].
CY2 Cycle 2 parameters family.			
	Ln2	1	Long Wash Phase [min].
	Sh2	42	Short Wash Phase [s].
	PA2	4	Pause [s].
	r i2	12	Rinse Phase Duration [s].
	dr2	25	Drain [s].
	FP2	2	Final Pause [s].
CY3 Cycle 3 parameters family.			
	Ln3	3	Long Wash Phase [min].
	Sh3	42	Short Wash Phase [s].
	PA3	4	Pause [s].
	r i3	12	Rinse Phase Duration [s].
	dr3	25	Drain [s].
	FP3	2	Final Pause [s].
	bt3	0	Boiler Temperature Threshold for Cycle 3.

**AUCAIDPWS****PROG 117**

drn	Drain parameters family.		
idr	30	Initial Drain Phase Duration [s].	
fdr	80	Final Drain Phase Duration [s].	
drt	0	Drain and cleaning mode.	
cbd	0	Wash tank water change frequency control disabled.	
dPA	Set other parameters.		
ipa	0	Initial Pause [s] (for ALL cycles).	
dly	3	Delay for the 2 nd wash pump [s].	
pdr	0	Drain Phase Duration at the end of washing phase [s].	
rPA	0	Duration of pause after the rinse cycle [s] (for ALL cycles).	
CF	0	Degrees Celsius display.	
rit	0	During the rinse stage, the display shows the boiler temperature.	
HCP	Enter into HCP parameter family and set the following parameters.		
SEr	9	Dishwasher with incorporated continuous water softener.	
6. Switch OFF and then switch ON the machine.			
GEN	Enter into GEN parameter family.		
dIn	50	Initial Detergent Dosage.	
rIn	10	Initial Rinse Aid Dosage.	
dEt	6	Detergent dispensing during the wash cycle (loading during wash stage).	
rA,	4	Rinse aid dispensing during the rinse cycle (loading during boiler filling stage).	
7. Switch OFF and then switch ON the machine.			

WARNING:

To set the board parameters , carefully follow the order given in this programming file, from point 1 to point 7.

WARNING:

When modifying parameter *dFL* , all the parameters (except those belonging to the *CFG* family) assume the default values according to the tables in section 11 DEFAULT VALUES. The parameters of the *CFG* family are not modified.

**NHT / KHT / EHT****PROG 118**

1. Switch OFF and then switch ON the machine.

2. **CFG** Enter into CFG parameter family and set the following parameters:

LYP	0	Hood Type and undercounter.
boi	1	Pressure boiler.
dao	1	Manual Hood.
dFl	1	Default values for Hood Type models.
trc	0	Disabled (for this appliance SOFT START is NOT possible)..
b.t	1	Tank heater works only if boiler temperature reached.
btF	0	The tank is filled into the traditional way.
LES	0	Detergent level switches not enabled.
U1	0	ACTIVE function disabled.
rE	0	Regeneration cycle disabled (only for dishwashers with non-continuous water softener).
Alr	1	Alarms enabled.
RAE	0	Boiler electronic level sensor.
FrG	0	Resin regeneration cycle forcing.
SrU	10	Rinse water max. hardness.
bPo	50	Boiler heating control.

3. Switch OFF and then switch ON the machine.

4. Modify Factory parameters:

FAC Enter into FAC parameter family and set the following parameters.

btT	84	Boiler Temperature Threshold.
bH1	96	Boiler temperature: alarm threshold.
BAJ	0	Boiler Temperature Adjust.
bP	1	Boiler standby function enabled.
bSt	1	Booster Function.
btD	0	During stand-by boiler is kept at lower temperature than Temperature Threshold.
tT	63	Tub Temperature: Threshold.
tH1	75	Tank temperature: alarm threshold.

5. Modify the cycle parameters:

CY1 Cycle 1 parameters family.

Ln1	0	Long Wash Phase [min].
Sh1	34	Short Wash Phase [s].
PA1	4	Pause [s].
r1	16	Rinse Phase Duration [s].
dr1	30	Drain [s].
FP1	0	Final Pause [s].

CY2 Cycle 2 parameters family.

Ln2	1	Long Wash Phase [min].
Sh2	10	Short Wash Phase [s].
PA2	4	Pause [s].
r2	16	Rinse Phase Duration [s].
dr2	30	Drain [s].
FP2	0	Final Pause [s].

CY3 Cycle 3 parameters family.

Ln3	2	Long Wash Phase [min].
Sh3	10	Short Wash Phase [s].
PA3	4	Pause [s].
r3	16	Rinse Phase Duration [s].
dr3	30	Drain [s].
FP3	0	Final Pause [s].
bt3	0	Boiler Temperature Threshold for Cycle 3.



NHT / KHT / EHT		PROG 118	
drn	Drain parameters family.		
idr	40	Initial Drain Phase Duration [s].	
fdr	80	Final Drain Phase Duration [s].	
drt	0	Drain and cleaning mode.	
cbd	0	Wash tank water change frequency control disabled.	
dPA	Set other parameters.		
ipa	0	Initial Pause [s] (for ALL cycles).	
dly	3	Delay for the 2 nd wash pump [s].	
pdr	0	Drain Phase Duration at the end of washing phase [s].	
rPA	0	Duration of pause after the rinse cycle [s] (for ALL cycles).	
CF	0	Degrees Celsius display.	
rit	0	During the rinse stage, the display shows the boiler temperature.	
HCP	Enter into HCP parameter family and set the following parameters.		
SEr	1	Machine arranged for remote connection to PC.	
6. Switch OFF and then switch ON the machine.			
GE_n	Enter into GEn parameter family.		
dIn	90	Initial Detergent Dosage.	
rIn	10	Initial Rinse Aid Dosage.	
dEt	8	Detergent dispensing during the wash cycle (loading during wash stage).	
rA_i	4	Rinse aid dispensing during the rinse cycle (loading during boiler filling stage).	
7. Switch OFF and then switch ON the machine.			

WARNING:

To set the board parameters , carefully follow the order given in this programming file, from point 1 to point 7.

WARNING:

When modifying parameter **dFL** , all the parameters (except those belonging to the **CFG** family) assume the default values according to the tables in section 11 DEFAULT VALUES. The parameters of the **CFG** family are not modified.

**NHTG / EHTG****PROG 119**

1. Switch OFF and then switch ON the machine.

2. **CFG** Enter into CFG parameter family and set the following parameters:

tYP	0	Hood Type and undercounter.
boi	0	Atmospheric boiler.
dao	1	Manual Hood.
dFl	1	Default values for Hood Type models.
trc	0	Disabled (for this appliance SOFT START is NOT possible).
b.t	1	Tank heater works only if boiler temperature reached.
btF	75	Enable filling tank by means of rinsing cycles.
LES	0	Detergent level switches not enabled.
U1	0	ACTIVE function disabled.
rE	0	Regeneration cycle disabled (only for dishwashers with non-continuous water softener).
Alr	1	Alarms enabled.
RAE	0	Boiler electronic level sensor.
FrG	0	Resin regeneration cycle forcing.
SrU	10	Rinse water max. hardness.
bPo	50	Boiler heating control.

3. Switch OFF and then switch ON the machine.

4. Modify Factory parameters:

FAC Enter into FAC parameter family and set the following parameters.

btT	82	Boiler Temperature Threshold.
bH1	96	Boiler temperature: alarm threshold.
BAJ	0	Boiler Temperature Adjust.
bP	1	Boiler standby function enabled.
bSt	1	Booster Function.
btD	0	During stand-by boiler is kept at lower temperature than Temperature Threshold.
tT	63	Tub Temperature: Threshold.
tH1	75	Tank temperature: alarm threshold.

5. Modify the cycle parameters:

CY1 Cycle 1 parameters family.

Ln1	0	Long Wash Phase [min].
Sh1	36	Short Wash Phase [s].
PA1	4	Pause [s].
r1	12	Rinse Phase Duration [s].
dr1	25	Drain [s].
FP1	2	Final Pause [s].

CY2 Cycle 2 parameters family.

Ln2	1	Long Wash Phase [min].
Sh2	12	Short Wash Phase [s].
PA2	4	Pause [s].
r2	12	Rinse Phase Duration [s].
dr2	25	Drain [s].
FP2	2	Final Pause [s].

CY3 Cycle 3 parameters family.

Ln3	2	Long Wash Phase [min].
Sh3	12	Short Wash Phase [s].
PA3	4	Pause [s].
r3	12	Rinse Phase Duration [s].
dr3	25	Drain [s].
FP3	2	Final Pause [s].
bt3	0	Boiler Temperature Threshold for Cycle 3.



NHTG / EHTG		PROG 119
drn	Drain parameters family.	
idr	40	Initial Drain Phase Duration [s].
fdr	80	Final Drain Phase Duration [s].
drt	0	Drain and cleaning mode.
cbd	0	Wash tank water change frequency control disabled.
dPA	Set other parameters.	
ipa	0	Initial Pause [s] (for ALL cycles).
dly	3	Delay for the 2 nd wash pump [s].
pdr	0	Drain Phase Duration at the end of washing phase [s].
rPA	0	Duration of pause after the rinse cycle [s] (for ALL cycles).
CF	0	Degrees Celsius display.
rit	0	During the rinse stage, the display shows the boiler temperature.
HCP	Enter into HCP parameter family and set the following parameters.	
SEr	1	Machine arranged for remote connection to PC.
6. Switch OFF and then switch ON the machine.		
GE_n	Enter into GEn parameter family.	
dIn	90	Initial Detergent Dosage.
rIn	10	Initial Rinse Aid Dosage.
dEt	6	Detergent dispensing during the wash cycle (loading during wash stage).
rA_i	4	Rinse aid dispensing during the rinse cycle (loading during boiler filling stage).
7. Switch OFF and then switch ON the machine.		

WARNING:

To set the board parameters , carefully follow the order given in this programming file, from point 1 to point 7.

WARNING:

When modifying parameter **dFL** , all the parameters (except those belonging to the **CFG** family) assume the default values according to the tables in section 11 DEFAULT VALUES. The parameters of the **CFG** family are not modified.



ZHTA / AHTA / EHTA

PROG 120

1. Switch OFF and then switch ON the machine.

2. **CFG** Enter into CFG parameter family and set the following parameters:

LYP	0	Hood Type and undercounter.
bo1	0	Atmospheric boiler.
dao	1	Manual Hood.
dFL	1	Default values for Hood Type models.
trc	0	Disabled (for this appliance SOFT START is NOT possible).
b.t	1	Tank heater works only if boiler temperature reached.
btF	75	Enable filling tank by means of rinsing cycles.
LES	0	Detergent level switches not enabled.
U1	9	Select user interface hood type/ undercounter model.
rE	0	Regeneration cycle disabled (only for dishwashers with non-continuous water softener).
Alr	1	Alarms enabled.
AAE	0	Boiler electronic level sensor.
FrE	0	Resin regeneration cycle forcing.
SrU	10	Rinse water max. hardness.
bPo	50	Boiler heating control.

3. Switch OFF and then switch ON the machine.

4. Modify Factory parameters:

FAC Enter into FAC parameter family and set the following parameters.

btE	70	Boiler Temperature Threshold.
bH1	96	Boiler temperature: alarm threshold.
BAJ	4	Boiler Temperature Adjust.
bP	1	Boiler standby function enabled.
bSt	2	Booster Function.
btD	0	During stand-by boiler is kept at lower temperature than Temperature Threshold.
ttE	63	Tub Temperature: Threshold.
tH1	75	Tank temperature: alarm threshold.

5. Modify the cycle parameters:

Y1 Cycle 1 parameters family.

Ln1	0	Long Wash Phase [min].
Sh1	36	Short Wash Phase [s].
PA1	4	Pause [s].
ri1	12	Rinse Phase Duration [s].
dr1	25	Drain [s].
FP1	2	Final Pause [s].

Y2 Cycle 2 parameters family.

Ln2	1	Long Wash Phase [min].
Sh2	12	Short Wash Phase [s].
PA2	4	Pause [s].
ri2	12	Rinse Phase Duration [s].
dr2	25	Drain [s].
FP2	2	Final Pause [s].

Y3 Cycle 3 parameters family.

Ln3	2	Long Wash Phase [min].
Sh3	12	Short Wash Phase [s].
PA3	4	Pause [s].
ri3	12	Rinse Phase Duration [s].
dr3	25	Drain [s].
FP3	2	Final Pause [s].
bt3	0	Boiler Temperature Threshold for Cycle 3.

**ZHTA / AHTA / EHTA****PROG 120**

drn	Drain parameters family.		
ldr	40	Initial Drain Phase Duration [s].	
fdr	80	Final Drain Phase Duration [s].	
drt	0	Drain and cleaning mode.	
cbd	0	Wash tank water change frequency control disabled.	
dPA	Set other parameters.		
ipa	0	Initial Pause [s] (for ALL cycles).	
dly	3	Delay for the 2 nd wash pump [s].	
pdr	0	Drain Phase Duration at the end of washing phase [s].	
rPA	0	Duration of pause after the rinse cycle [s] (for ALL cycles).	
CF	0	Degrees Celsius display.	
rit	0	During the rinse stage, the display shows the boiler temperature.	
tLE	0	Thermal Label mode disabled (Functions present with firmware version 4.04).	
HCP	Enter into HCP parameter family and set the following parameters.		
SEr	1	Machine arranged for remote connection to PC.	
6. Switch OFF and then switch ON the machine.			
GEN	Enter into GEN parameter family.		
dIn	90	Initial Detergent Dosage.	
rIn	10	Initial Rinse Aid Dosage.	
dEt	6	Detergent dispensing during the wash cycle (loading during wash stage).	
rA_i	4	Rinse aid dispensing during the rinse cycle (loading during boiler filling stage).	
7. Switch OFF and then switch ON the machine.			

WARNING:

To set the board parameters , carefully follow the order given in this programming file, from point 1 to point 7.

WARNING:

When modifying parameter *dFL* , all the parameters (except those belonging to the *CFG* family) assume the default values according to the tables in section 11 DEFAULT VALUES. The parameters of the *CFG* family are not modified.

**ZHTAWS/ AHTAWS/ EHTAWS PROG 121**

1. Switch OFF and then switch ON the machine.

2. **CFG** Enter into CFG parameter family and set the following parameters:

tYP	0	Hood Type and undercounter.
boi	0	Atmospheric boiler.
dao	1	Manual Hood.
dFl	1	Default values for Hood Type models.
trc	0	Disabled (for this appliance SOFT START is NOT possible).
b.t	1	Tank heater works only if boiler temperature reached.
btF	75	Enable filling tank by means of rinsing cycles.
LES	0	Detergent level switches not enabled.
U1	9	Select user interface hood type/ undercounter model.
rE	0	Regeneration cycle disabled (only for dishwashers with non-continuous water softener).
Alr	1	Alarms enabled.
AAc	1	Boiler float level sensor.
FrC	0	Resin regeneration cycle forcing.
SrU	10	Rinse water max. hardness.
bPo	50	Boiler heating control.

3. Switch OFF and then switch ON the machine.

4. Modify Factory parameters:

FAC Enter into FAC parameter family and set the following parameters.

btC	70	Boiler Temperature Threshold.
bH1	96	Boiler temperature: alarm threshold.
BAJ	4	Boiler Temperature Adjust.
bP	1	Boiler standby function enabled.
bSt	2	Booster Function.
btD	0	During stand-by boiler is kept at lower temperature than Temperature Threshold.
tC	63	Tub Temperature: Threshold.
tH1	75	Tank temperature: alarm threshold.

5. Modify the cycle parameters:

CY1 Cycle 1 parameters family.

Ln1	0	Long Wash Phase [min].
Sh1	36	Short Wash Phase [s].
PA1	4	Pause [s].
r1	12	Rinse Phase Duration [s].
dr1	25	Drain [s].
FP1	2	Final Pause [s].

CY2 Cycle 2 parameters family.

Ln2	1	Long Wash Phase [min].
Sh2	12	Short Wash Phase [s].
PA2	4	Pause [s].
r2	12	Rinse Phase Duration [s].
dr2	25	Drain [s].
FP2	2	Final Pause [s].

CY3 Cycle 3 parameters family.

Ln3	2	Long Wash Phase [min].
Sh3	12	Short Wash Phase [s].
PA3	4	Pause [s].
r3	12	Rinse Phase Duration [s].
dr3	25	Drain [s].
FP3	2	Final Pause [s].
bt3	0	Boiler Temperature Threshold for Cycle 3.

**ZHTAWS/ AHTAWS/ EHTAWS PROG 121**

drn	Drain parameters family.	
idr	40	Initial Drain Phase Duration [s].
fdr	100	Final Drain Phase Duration [s].
drt	0	Drain and cleaning mode.
cbd	0	Wash tank water change frequency control disabled.
dPA	Set other parameters.	
ipa	0	Initial Pause [s] (for ALL cycles).
dly	3	Delay for the 2 nd wash pump [s].
pdr	0	Drain Phase Duration at the end of washing phase [s].
rPA	0	Duration of pause after the rinse cycle [s] (for ALL cycles).
CF	0	Degrees Celsius display.
rit	0	During the rinse stage, the display shows the boiler temperature.
HCP	Enter into HCP parameter family and set the following parameters.	
SEr	9	Dishwasher with incorporated continuous water softener.
6. Switch OFF and then switch ON the machine.		
GE_n	Enter into GEn parameter family.	
dIn	90	Initial Detergent Dosage.
rIn	10	Initial Rinse Aid Dosage.
dEt	6	Detergent dispensing during the wash cycle (loading during wash stage).
rA_i	4	Rinse aid dispensing during the rinse cycle (loading during boiler filling stage).
7. Switch OFF and then switch ON the machine.		

WARNING:

To set the board parameters , carefully follow the order given in this programming file, from point 1 to point 7.

WARNING:

When modifying parameter *dFL* , all the parameters (except those belonging to the *CFG* family) assume the default values according to the tables in section 11 DEFAULT VALUES. The parameters of the *CFG* family are not modified.



ZHTAIAU / EHTAIAU

PROG 122

1. Switch OFF and then switch ON the machine.

2. **CFG** Enter into CFG parameter family and set the following parameters:

tYP	0	Hood Type and undercounter.
bo1	0	Atmospheric boiler.
dao	0	Automatic Hood.
dFL	1	Default values for Hood Type models.
trc	0	Disabled (for this appliance SOFT START is NOT possible).
b.t	1	Tank heater works only if boiler temperature reached.
btF	75	Enable filling tank by means of rinsing cycles.
LES	0	Detergent level switches not enabled.
U1	9	Select user interface hood type/ undercounter model.
rE	0	Regeneration cycle disabled (only for dishwashers with non-continuous water softener).
Alr	1	Alarms enabled.
AAE	0	Boiler electronic level sensor.
FrE	0	Resin regeneration cycle forcing.
SrU	10	Rinse water max. hardness.
bPo	50	Boiler heating control.

3. Switch OFF and then switch ON the machine.

4. Modify Factory parameters:

FAC Enter into FAC parameter family and set the following parameters.

btE	70	Boiler Temperature Threshold.
bH1	96	Boiler temperature: alarm threshold.
BAJ	4	Boiler Temperature Adjust.
bP	1	Boiler standby function enabled.
bSt	2	Booster Function.
btD	0	During stand-by boiler is kept at lower temperature than Temperature Threshold.
tE	63	Tub Temperature: Threshold.
tH1	75	Tank temperature: alarm threshold.

5. Modify the cycle parameters:

CY1 Cycle 1 parameters family.

Ln1	0	Long Wash Phase [min].
Sh1	36	Short Wash Phase [s].
PA1	4	Pause [s].
r1	12	Rinse Phase Duration [s].
dr1	25	Drain [s].
FP1	2	Final Pause [s].

CY2 Cycle 2 parameters family.

Ln2	1	Long Wash Phase [min].
Sh2	12	Short Wash Phase [s].
PA2	4	Pause [s].
r2	12	Rinse Phase Duration [s].
dr2	25	Drain [s].
FP2	2	Final Pause [s].

CY3 Cycle 3 parameters family.

Ln3	2	Long Wash Phase [min].
Sh3	12	Short Wash Phase [s].
PA3	4	Pause [s].
r3	12	Rinse Phase Duration [s].
dr3	25	Drain [s].
FP3	2	Final Pause [s].
bt3	0	Boiler Temperature Threshold for Cycle 3.

**ZHTAIAU / EHTAIAU****PROG 122**

drn	Drain parameters family.		
idr	40	Initial Drain Phase Duration [s].	
fdr	80	Final Drain Phase Duration [s].	
drt	0	Drain and cleaning mode.	
lbd	0	Wash tank water change frequency control disabled.	
dPA	Set other parameters.		
ipa	2	Initial Pause [s] (for ALL cycles).	
dly	3	Delay for the 2 nd wash pump [s].	
pdr	0	Drain Phase Duration at the end of washing phase [s].	
rPA	0	Duration of pause after the rinse cycle [s] (for ALL cycles).	
CF	0	Degrees Celsius display.	
rit	0	During the rinse stage, the display shows the boiler temperature.	
HCP	Enter into HCP parameter family and set the following parameters.		
SEr	1	Machine arranged for remote connection to PC.	
6. Switch OFF and then switch ON the machine.			
GE_n	Enter into GEn parameter family.		
dln	90	Initial Detergent Dosage.	
rln	10	Initial Rinse Aid Dosage.	
dEt	6	Detergent dispensing during the wash cycle (loading during wash stage).	
rA_i	4	Rinse aid dispensing during the rinse cycle (loading during boiler filling stage).	
7. Switch OFF and then switch ON the machine.			

WARNING:

To set the board parameters , carefully follow the order given in this programming file, from point 1 to point 7.

WARNING:

When modifying parameter *dFL* , all the parameters (except those belonging to the *CFG* family) assume the default values according to the tables in section 11 DEFAULT VALUES. The parameters of the *CFG* family are not modified.



EHTAIMLAU

PROG 123

1. Switch OFF and then switch ON the machine.		
2.	CFG	Enter into CFG parameter family and set the following parameters:
	tYP	0 Hood Type and undercounter.
	bo1	0 Atmospheric boiler.
	dao	0 Automatic Hood.
	dFl	1 Default values for Hood Type models.
	trc	0 Disabled (for this appliance SOFT START is NOT possible).
	b.t	1 Tank heater works only if boiler temperature reached.
	btF	75 Enable filling tank by means of rinsing cycles.
	LES	0 Detergent level switches not enabled.
	U1	9 Select user interface hood type/ undercounter model.
	rE	0 Regeneration cycle disabled (only for dishwashers with non-continuous water softener).
	Alr	1 Alarms enabled.
	AAE	0 Boiler electronic level sensor.
	FrG	0 Resin regeneration cycle forcing.
	SrU	10 Rinse water max. hardness.
	bPo	50 Boiler heating control.
3. Switch OFF and then switch ON the machine.		
4. Modify Factory parameters:		
	FAC	Enter into FAC parameter family and set the following parameters.
	btT	90 Boiler Temperature Threshold.
	bH1	0 Disable boiler high Temperature alarm (1 2).
	BAJ	0 Boiler Temperature Adjust.
	bP	1 Boiler standby function enabled.
	bSt	2 Booster Function.
	btD	0 During stand-by boiler is kept at lower temperature than Temperature Threshold.
	tT	65 Tub Temperature: Threshold.
	tH1	85 Tank temperature: alarm threshold.
5. Modify the cycle parameters:		
	Y1	Cycle 1 parameters family.
	Ln1	2 Long Wash Phase [min].
	Sh1	32 Short Wash Phase [s].
	PA1	4 Pause [s].
	r1	35 Rinse Phase Duration [s].
	dr1	40 Drain [s].
	FP1	15 Final Pause [s].
	Y2	Cycle 2 parameters family.
	Ln2	3 Long Wash Phase [min].
	Sh2	32 Short Wash Phase [s].
	PA2	4 Pause [s].
	r2	35 Rinse Phase Duration [s].
	dr2	40 Drain [s].
	FP2	15 Final Pause [s].
	Y3	Cycle 3 parameters family.
	Ln3	5 Long Wash Phase [min].
	Sh3	32 Short Wash Phase [s].
	PA3	4 Pause [s].
	r3	34 Rinse Phase Duration [s].
	dr3	40 Drain [s].
	FP3	15 Final Pause [s].
	bt3	0 Boiler Temperature Threshold for Cycle 3.

**EHTAIMLAU****PROG 123**

drn	Drain parameters family.		
idr	40	Initial Drain Phase Duration [s].	
fdr	80	Final Drain Phase Duration [s].	
drt	0	Drain and cleaning mode.	
cbd	0	Wash tank water change frequency control disabled.	
dPA	Set other parameters.		
ipa	4	Initial Pause [s] (for ALL cycles).	
dly	3	Delay for the 2 nd wash pump [s].	
pdr	0	Drain Phase Duration at the end of washing phase [s].	
rPA	0	Duration of pause after the rinse cycle [s] (for ALL cycles).	
CF	0	Degrees Celsius display.	
rit	0	During the rinse stage, the display shows the boiler temperature.	
HCP	Enter into HCP parameter family and set the following parameters.		
SEr	1	Machine arranged for remote connection to PC.	
6. Switch OFF and then switch ON the machine.			
GE_n	Enter into GEn parameter family.		
dIn	90	Initial Detergent Dosage.	
rIn	10	Initial Rinse Aid Dosage.	
dEt	8	Detergent dispensing during the wash cycle (loading during wash stage).	
rA_i	4	Rinse aid dispensing during the rinse cycle (loading during boiler filling stage).	
7. Switch OFF and then switch ON the machine.			

WARNING:

To set the board parameters , carefully follow the order given in this programming file, from point 1 to point 7.

WARNING:

When modifying parameter **dFL** , all the parameters (except those belonging to the **CFG** family) assume the default values according to the tables in section 11 DEFAULT VALUES. The parameters of the **CFG** family are not modified.



ZHTAROW / EHTAROW / ZHTAO / EHTAO

PROG 124

1. Switch OFF and then switch ON the machine.

2. **CFG** Enter into CFG parameter family and set the following parameters:

tYP	0	Hood Type and undercounter.
bo	0	Atmospheric boiler.
doo	1	Manual Hood.
dFl	1	Default values for Hood Type models.
trc	0	Disabled (for this appliance SOFT START is NOT possible).
b.t	0	Boiler heaters and tank heater work simultaneously.
b.tF	75	Enable filling tank by means of rinsing cycles.
LES	0	Detergent level switches not enabled.
U1	9	Select user interface hood type/ undercounter model.
rE	0	Regeneration cycle disabled (only for dishwashers with non-continuous water softener).
Alr	1	Alarms enabled.
RAE	0	Boiler electronic level sensor.
FrG	0	Resin regeneration cycle forcing.
SrU	10	Rinse water max. hardness.
bPo	50	Boiler heating control.

3. Switch OFF and then switch ON the machine.

4. Modify Factory parameters:

FAC Enter into FAC parameter family and set the following parameters.

b.tC	78	Boiler Temperature Threshold.
bH	0	Disable boiler high Temperature alarm (E 2).
bAJ	4	Boiler Temperature Adjust.
bP	1	Boiler standby function enabled.
bSt	2	Booster Function.
b.td	0	During stand-by boiler is kept at lower temperature than Temperature Threshold.
t.tC	63	Tank Temperature: Threshold.
tH	0	Disable tank high Temperature alarm (E 3).

5. Modify the cycle parameters:

CY1 Cycle 1 parameters family.

Ln1	0	Long Wash Phase [min].
Sh1	36	Short Wash Phase [s].
PA1	4	Pause [s].
r.i1	12	Rinse Phase Duration [s].
dr1	25	Drain [s].
FP1	2	Final Pause [s].
tL1	0	Long Wash Phase inTermal Label mode [min].
tS1	59	Short Wash Phase inTermal Label mode [s].

CY2 Cycle 2 parameters family.

Ln2	1	Long Wash Phase [min].
Sh2	12	Short Wash Phase [s].
PA2	4	Pause [s].
r.i2	12	Rinse Phase Duration [s].
dr2	25	Drain [s].
FP2	2	Final Pause [s].
tL2	1	Long Wash Phase inTermal Label mode [min].
tS2	12	Short Wash Phase inTermal Label mode [s].



ZHTAROW / EHTAROW / ZHTAO / EHTAO

PROG 124

LY3	Cycle 3 parameters family.	
LW3	2	Long Wash Phase [min].
SW3	12	Short Wash Phase [s].
PA3	4	Pause [s].
ri3	12	Rinse Phase Duration [s].
dr3	25	Drain [s].
FP3	2	Final Pause [s].
TL3	2	Long Wash Phase in Termal Label mode [min].
TS3	12	Short Wash Phase in Termal Label mode [s].
bt3	0	Boiler Temperature Threshold for Cycle 3.
drn	Drain parameters family.	
idr	40	Initial Drain Phase Duration [s].
Fdr	80	Final Drain Phase Duration [s].
drt	0	Drain and cleaning mode.
cbd	0	Wash tank water change frequency control disabled.
dPA	Set other parameters.	
IPA	0	Initial Pause [s] (for ALL cycles).
dLY	3	Delay for the 2 nd wash pump [s].
Pdr	0	Drain Phase Duration at the end of washing phase [s].
rPA	0	Duration of pause after the rinse cycle [s] (for ALL cycles).
CF	0	Degrees Celsius display.
rit	0	During the rinse stage, the display shows the boiler temperature.
TLE	1	Termal Label mode enabled.
btL	86	Boiler Temperature in Termal Label mode.
ttL	75	Tank Temperature in Termal Label mode.
tHL	2	Tank Temperature histeresis in Termal Label mode.
HCP	Enter into HCP parameter family and set the following parameters.	
SEr	1	Machine arranged for remote connection to PC.
6. Switch OFF and then switch ON the machine.		
GEN	Enter into GEN parameter family.	
dIn	90	Initial Detergent Dosage.
riIn	10	Initial Rinse Aid Dosage.
dEt	6	Detergent dispensing during the wash cycle (loading during wash stage).
rAi	4	Rinse aid dispensing during the rinse cycle (loading during boiler filling stage).
7. Switch OFF and then switch ON the machine.		

WARNING:

To set the board parameters , carefully follow the order given in this programming file, from point 1 to point 7.

WARNING:

When modifying parameter **dFL** , all the parameters (except those belonging to the **CFG** family) assume the default values according to the tables in section 11 DEFAULT VALUES. The parameters of the **CFG** family are not modified.



EUCAIUSPH

PROG 125

1. Switch OFF and then switch ON the machine.

2. **CFG** Enter into CFG parameter family and set the following parameters:

LYP	0	Hood Type and undercounter.
bo1	0	Atmospheric boiler.
dao	2	Manual Hood.
dFl	3	Default values for Hood Type models.
trc	0	Disabled (for this appliance SOFT START is NOT possible).
b.t	1	Tank heater works only if boiler temperature reached.
btf	75	Enable filling tank by means of rinsing cycles.
LES	0	Detergent level switches not enabled.
U1	9	Select user interface hood type/ undercounter model.
rE	0	Regeneration cycle disabled (only for dishwashers with non-continuous water softener).
Alr	1	Alarms enabled.
AAE	0	Boiler electronic level sensor.
FrE	0	Resin regeneration cycle forcing.
SrU	10	Rinse water max. hardness.
bPo	50	Boiler heating control.

3. Switch OFF and then switch ON the machine.

4. Modify Factory parameters:

FAC Enter into FAC parameter family and set the following parameters.

bte	82	Boiler Temperature Threshold.
bH1	96	Boiler temperature: alarm threshold.
BAJ	4	Boiler Temperature Adjust.
bP	1	Boiler standby function enabled.
bSt	0	Booster Function.
btd	3	During stand-by boiler is kept at lower temperature than Temperature Threshold.
teE	66	Tub Temperature: Threshold.
tH1	80	Tank temperature: alarm threshold.

5. Modify the cycle parameters:

CY1 Cycle 1 parameters family.

Ln1	1	Long Wash Phase [min].
Sh1	22	Short Wash Phase [s].
PA1	4	Pause [s].
ri1	25	Rinse Phase Duration [s].
dr1	40	Drain [s].
FP1	4	Final Pause [s].

CY2 Cycle 2 parameters family.

Ln2	2	Long Wash Phase [min].
Sh2	22	Short Wash Phase [s].
PA2	4	Pause [s].
ri2	25	Rinse Phase Duration [s].
dr2	40	Drain [s].
FP2	4	Final Pause [s].

CY3 Cycle 3 parameters family.

Ln3	4	Long Wash Phase [min].
Sh3	22	Short Wash Phase [s].
PA3	4	Pause [s].
ri3	25	Rinse Phase Duration [s].
dr3	40	Drain [s].
FP3	4	Final Pause [s].
bte3	0	Boiler Temperature Threshold for Cycle 3.

**EUCAIUSPH****PROG 125**

drn	Drain parameters family.		
idr	30	Initial Drain Phase Duration [s].	
fdr	00	Final Drain Phase Duration [s].	
drt	0	Drain and cleaning mode.	
cbd	0	Wash tank water change frequency control disabled.	
dPA	Set other parameters.		
ipa	5	Initial Pause [s] (for ALL cycles).	
dly	3	Delay for the 2 nd wash pump [s].	
pdr	0	Drain Phase Duration at the end of washing phase [s].	
rPA	0	Duration of pause after the rinse cycle [s] (for ALL cycles).	
CF	1	Degrees display Fahrenheit.	
rit	0	During the rinse stage, the display shows the boiler temperature.	
HCP	Enter into HCP parameter family and set the following parameters.		
SEr	1	Machine arranged for remote connection to PC.	
6. Switch OFF and then switch ON the machine.			
GEr	Enter into GEn parameter family.		
dIn	50	Initial Detergent Dosage.	
rIn	10	Initial Rinse Aid Dosage.	
dEt	8	Detergent dispensing during the wash cycle (loading during wash stage).	
rA1	4	Rinse aid dispensing during the rinse cycle (loading during boiler filling stage).	
7. Switch OFF and then switch ON the machine.			

WARNING:

To set the board parameters , carefully follow the order given in this programming file, from point 1 to point 7.

WARNING:

When modifying parameter **dFL** , all the parameters (except those belonging to the **CFG** family) assume the default values according to the tables in section 11 DEFAULT VALUES. The parameters of the **CFG** family are not modified.



EHTAIUSPH

PROG 126

1. Switch OFF and then switch ON the machine.

2. **CFG** Enter into CFG parameter family and set the following parameters:

tYP	0	Hood Type and undercounter.
boi	0	Atmospheric boiler.
dao	1	Manual Hood.
dFL	1	Default values for Hood Type models.
trc	0	Disabled (for this appliance SOFT START is NOT possible).
b.t	1	Tank heater works only if boiler temperature reached.
btF	75	Enable filling tank by means of rinsing cycles.
LES	0	Detergent level switches not enabled.
U1	9	Select user interface hood type/ undercounter model.
rE	0	Regeneration cycle disabled (only for dishwashers with non-continuous water softener).
Alr	1	Alarms enabled.
AAE	0	Boiler electronic level sensor.
FrE	0	Resin regeneration cycle forcing.
SrU	10	Rinse water max. hardness.
bPo	50	Boiler heating control.

3. Switch OFF and then switch ON the machine.

4. Modify Factory parameters:

FAC Enter into FAC parameter family and set the following parameters.

btE	70	Boiler Temperature Threshold.
bH1	96	Boiler temperature: alarm threshold.
BAJ	4	Boiler Temperature Adjust.
bP	1	Boiler standby function enabled.
bSt	2	Booster Function.
btD	0	During stand-by boiler is kept at lower temperature than Temperature Threshold.
tE	63	Tub Temperature: Threshold.
tH1	75	Tank temperature: alarm threshold.

5. Modify the cycle parameters:

CY1 Cycle 1 parameters family.

Ln1	0	Long Wash Phase [min].
Sh1	35	Short Wash Phase [s].
PA1	4	Pause [s].
ri1	25	Rinse Phase Duration [s].
dr1	25	Drain [s].
FP1	0	Final Pause [s].

CY2 Cycle 2 parameters family.

Ln2	0	Long Wash Phase [min].
Sh2	45	Short Wash Phase [s].
PA2	4	Pause [s].
ri2	25	Rinse Phase Duration [s].
dr2	25	Drain [s].
FP2	0	Final Pause [s].

CY3 Cycle 3 parameters family.

Ln3	1	Long Wash Phase [min].
Sh3	40	Short Wash Phase [s].
PA3	4	Pause [s].
ri3	25	Rinse Phase Duration [s].
dr3	25	Drain [s].
FP3	0	Final Pause [s].
bt3	0	Boiler Temperature Threshold for Cycle 3.

**EHTAIUSPH****PROG 126**

drn	Drain parameters family.	
idr	40	Initial Drain Phase Duration [s].
fdr	80	Final Drain Phase Duration [s].
drt	0	Drain and cleaning mode.
cbd	0	Wash tank water change frequency control disabled.
dPA	Set other parameters.	
ipa	0	Initial Pause [s] (for ALL cycles).
dly	3	Delay for the 2 nd wash pump [s].
pdr	0	Drain Phase Duration at the end of washing phase [s].
rPA	0	Duration of pause after the rinse cycle [s] (for ALL cycles).
CF	1	Degrees display Fahrenheit.
rit	0	During the rinse stage, the display shows the boiler temperature.
HCP	Enter into HCP parameter family and set the following parameters.	
SEr	1	Machine arranged for remote connection to PC.
6. Switch OFF and then switch ON the machine.		
GEN	Enter into GEN parameter family.	
dln	90	Initial Detergent Dosage.
rin	10	Initial Rinse Aid Dosage.
dEt	8	Detergent dispensing during the wash cycle (loading during wash stage).
rA,	4	Rinse aid dispensing during the rinse cycle (loading during boiler filling stage).
7. Switch OFF and then switch ON the machine.		

WARNING:

To set the board parameters , carefully follow the order given in this programming file, from point 1 to point 7.

WARNING:

When modifying parameter *dFL* , all the parameters (except those belonging to the *CFG* family) assume the default values according to the tables in section 11 DEFAULT VALUES. The parameters of the *CFG* family are not modified.

**OHTAROW / OHTAROW60****PROG 127**

1. Switch OFF and then switch ON the machine.

2. **CFG** Enter into CFG parameter family and set the following parameters:

tyP	0	Hood Type and undercounter.
bo1	0	Atmospheric boiler.
dao	1	Manual Hood.
dFl	1	Default values for Hood Type models.
trc	0	Disabled (for this appliance SOFT START is NOT possible).
b.t	0	Boiler heaters and tank heater work simultaneously.
b.tF	75	Enable filling tank by means of rinsing cycles.
LES	0	Detergent level switches not enabled.
U1	9	Select user interface hood type/ undercounter model.
rE	0	Regeneration cycle disabled (only for dishwashers with non-continuous water softener).
Alr	1	Alarms enabled.
AAE	0	Boiler electronic level sensor.
FrE	0	Resin regeneration cycle forcing.
SrU	10	Rinse water max. hardness.
bPo	50	Boiler heating control.

3. Switch OFF and then switch ON the machine.

4. Modify Factory parameters:

FAC Enter into FAC parameter family and set the following parameters.

b.tE	70	Boiler Temperature Threshold.
bH1	0	Disable boiler high Temperature alarm (E 2).
BAJ	4	Boiler Temperature Adjust.
bP	1	Boiler standby function enabled.
bSt	2	Booster Function.
b.td	0	During stand-by boiler is kept at lower temperature than Temperature Threshold.
t.tE	63	Tank Temperature: Threshold.
t.H1	0	Disable tank high Temperature alarm (E 3).

5. Modify the cycle parameters:

EY1 Cycle 1 parameters family.

Ln1	0	Long Wash Phase [min].
Sh1	36	Short Wash Phase [s].
PA1	4	Pause [s].
r11	12	Rinse Phase Duration [s].
dr1	25	Drain [s].
FP1	2	Final Pause [s].
tL1	0	Long Wash Phase inTermal Label mode [min].
tS1	59	Short Wash Phase inTermal Label mode [s].

EY2 Cycle 2 parameters family.

Ln2	1	Long Wash Phase [min].
Sh2	12	Short Wash Phase [s].
PA2	4	Pause [s].
r12	12	Rinse Phase Duration [s].
dr2	25	Drain [s].
FP2	2	Final Pause [s].
tL2	1	Long Wash Phase inTermal Label mode [min].
tS2	12	Short Wash Phase inTermal Label mode [s].

**OHTAROW / OHTAROW60****PROG 127**

LY3	Cycle 3 parameters family.	
Ln3	2	Long Wash Phase [min].
Sh3	12	Short Wash Phase [s].
PA3	4	Pause [s].
r i3	12	Rinse Phase Duration [s].
dr3	25	Drain [s].
FP3	2	Final Pause [s].
bt3	0	Boiler Temperature Threshold for Cycle 3.
tL3	2	Long Wash Phase inTernal Label mode [min].
tS3	12	Short Wash Phase inTernal Label mode [s].
drn	Drain parameters family.	
ldr	40	Initial Drain Phase Duration [s].
Fdr	80	Final Drain Phase Duration [s].
drk	0	Drain and cleaning mode.
cbd	0	Wash tank water change frequency control disabled.
dPA	Set other parameters.	
IPA	0	Initial Pause [s] (for ALL cycles).
dLY	3	Delay for the 2 nd wash pump [s].
Pdr	0	Drain Phase Duration at the end of washing phase [s].
rPA	0	Duration of pause after the rinse cycle [s] (for ALL cycles).
CF	0	Degrees Celsius display.
r it	0	During the rinse stage, the display shows the boiler temperature.
tLE	1	Ternal Label mode enabled.
btL	86	Boiler Temperature in Ternal Label mode.
tLl	75	Tank Temperature in Ternal Label mode.
tHt	2	Tank Temperature histeresis in Ternal Label mode.
HCP	Enter into HCP parameter family and set the following parameters.	
SEr	1	Machine arranged for remote connection to PC.
6. Switch OFF and then switch ON the machine.		
GE_n	Enter into GEn parameter family.	
dIn	90	Initial Detergent Dosage.
rIn	0	Initial Rinse Aid Dosage.
dEt	101	Detergent dispenser works when WASH PUMP in activated.
rA_i	51	Rinse Aid dispenser works when LOAD SOLENOID VALVE in activated.
7. Switch OFF and then switch ON the machine.		

WARNING:

To set the board parameters , carefully follow the order given in this programming file, from point 1 to point 7.

WARNING:

When modifying parameter **dFL** , all the parameters (except those belonging to the **LFU** family) assume the default values according to the tables in section 11 DEFAULT VALUES. The parameters of the **LFU** family are not modified.

**ZUCA****PROG 128**

1. Switch OFF and then switch ON the machine.

2. **CFG** Enter into CFG parameter family and set the following parameters:

LYP	0	Hood Type and undercounter.
bo1	0	Atmospheric boiler.
dao	2	Front loading function.
dFL	3	Default values for Undercounter models.
trc	1	SOFT START enabled.
b.t	1	Tank heater works only if boiler temperature reached.
btf	75	Enable filling tank by means of rinsing cycles.
LES	0	Detergent level switches not enabled.
U1	9	Select user interface hood type/ undercounter model.
rE	0	Regeneration cycle disabled.
Alr	0	Alarms not enabled.
AAE	0	Boiler electronic level sensor.
FrE	0	Resin regeneration cycle forcing.
SrU	10	Rinse water max. hardness.
bPo	50	Boiler heating control.

3. Switch OFF and then switch ON the machine.

4. Modify Factory parameters:

FAC Enter into FAC parameter family and set the following parameters.

bte	80	Boiler Temperature Threshold.
bH1	96	Boiler temperature: alarm threshold.
BAJ	0	Boiler Temperature Adjust.
bP	1	Boiler standby function enabled.
bSt	2	Booster Function.
btd	3	During stand-by boiler is kept at lower temperature than Temperature Threshold.
teE	63	Tub Temperature: Threshold.
tH1	75	Tank temperature: alarm threshold.

5. Modify the cycle parameters:

CY1 Cycle 1 parameters family.

Ln1	1	Long Wash Phase [min].
Sh1	12	Short Wash Phase [s].
PA1	4	Pause [s].
r11	12	Rinse Phase Duration [s].
dr1	25	Drain [s].
FP1	2	Final Pause [s].

CY2 Cycle 2 parameters family.

Ln2	1	Long Wash Phase [min].
Sh2	42	Short Wash Phase [s].
PA2	4	Pause [s].
r12	12	Rinse Phase Duration [s].
dr2	25	Drain [s].
FP2	2	Final Pause [s].

CY3 Cycle 3 parameters family.

Ln3	3	Long Wash Phase [min].
Sh3	42	Short Wash Phase [s].
PA3	4	Pause [s].
r13	12	Rinse Phase Duration [s].
dr3	25	Drain [s].
FP3	2	Final Pause [s].
bte3	0	Boiler Temperature Threshold for Cycle 3.



ZUCA

PROG 128

drn	Drain parameters family.		
idr	30	Initial Drain Phase Duration [s].	
fdr	100	Final Drain Phase Duration [s].	
drt	0	Drain and cleaning mode.	
lbd	0	Wash tank water change frequency control disabled.	
dPA	Set other parameters.		
ipa	0	Initial Pause [s] (for ALL cycles).	
dly	3	Delay for the 2 nd wash pump [s].	
pdr	0	Drain Phase Duration at the end of washing phase [s].	
rPA	0	Duration of pause after the rinse cycle [s] (for ALL cycles).	
CF	0	Degrees Celsius display.	
rit	0	During the rinse stage, the display shows the boiler temperature.	
HCP	Enter into HCP parameter family and set the following parameters.		
SEr	1	Machine arranged for remote connection to PC.	
6. Switch OFF and then switch ON the machine.			
GEN	Enter into GEN parameter family.		
dln	50	Initial Detergent Dosage.	
rin	10	Initial Rinse Aid Dosage.	
dEt	6	Detergent dispensing during the wash cycle (loading during wash stage).	
rA,	4	Rinse aid dispensing during the rinse cycle (loading during boiler filling stage).	
7. Switch OFF and then switch ON the machine.			

WARNING:

To set the board parameters , carefully follow the order given in this programming file, from point 1 to point 7.

WARNING:

When modifying parameter **dFL** , all the parameters (except those belonging to the **CFG** family) assume the default values according to the tables in section 11 DEFAULT VALUES. The parameters of the **CFG** family are not modified.



ET12AI

PROG 129

1. Switch OFF and then switch ON the machine.

2. **CFG** Enter into CFG parameter family and set the following parameters:

LYP	0	Hood Type and undercounter.
bo1	0	Atmospheric boiler.
dao	1	Manual Hood.
dFL	1	Default values for Hood Type models.
trc	1	SOFT START enabled.
b.t	0	Boiler heaters and tank heater work simultaneously.
btf	75	Enable filling tank by means of rinsing cycles.
LES	0	Detergent level switches not enabled.
U1	9	Select user interface hood type/ undercounter model.
rE	0	Regeneration cycle disabled (only for dishwashers with non-continuous water softener).
Alr	1	Alarms enabled.
RAE	0	Boiler electronic level sensor.
FrG	0	Resin regeneration cycle forcing.
SrU	10	Rinse water max. hardness.
bPo	50	Boiler heating control.

3. Switch OFF and then switch ON the machine.

4. Modify Factory parameters:

FAC Enter into FAC parameter family and set the following parameters.

bTt	70	Boiler Temperature Threshold.
bH1	96	Boiler temperature: alarm threshold.
BAJ	4	Boiler Temperature Adjust.
bP	1	Boiler standby function enabled.
bSt	2	Booster Function.
btd	0	During stand-by boiler is kept at lower temperature than Temperature Threshold.
tTt	63	Tub Temperature: Threshold.
tH1	75	Tank temperature: alarm threshold.

5. Modify the cycle parameters:

CY1 Cycle 1 parameters family.

Ln1	1	Long Wash Phase [min].
Sh1	10	Short Wash Phase [s].
PA1	4	Pause [s].
r11	12	Rinse Phase Duration [s].
dr1	12	Drain [s].
FP1	4	Final Pause [s].

CY2 Cycle 2 parameters family.

Ln2	1	Long Wash Phase [min].
Sh2	40	Short Wash Phase [s].
PA2	4	Pause [s].
r12	12	Rinse Phase Duration [s].
dr2	12	Drain [s].
FP2	4	Final Pause [s].

CY3 Cycle 3 parameters family.

Ln3	1	Long Wash Phase [min].
Sh3	32	Short Wash Phase [s].
PA3	4	Pause [s].
r13	20	Rinse Phase Duration [s].
dr3	20	Drain [s].
FP3	4	Final Pause [s].
bT3	65	Boiler Temperature Threshold for Cycle 3.

**ET12AI****PROG 129**

drn	Drain parameters family.		
ldr	40	Initial Drain Phase Duration [s].	
fdr	80	Final Drain Phase Duration [s].	
drt	0	Drain and cleaning mode.	
cbd	0	Wash tank water change frequency control disabled.	
dPA	Set other parameters.		
ipa	0	Initial Pause [s] (for ALL cycles).	
dly	3	Delay for the 2 nd wash pump [s].	
pdr	0	Drain Phase Duration at the end of washing phase [s].	
rPA	0	Duration of pause after the rinse cycle [s] (for ALL cycles).	
CF	0	Degrees Celsius display.	
rit	0	During the rinse stage, the display shows the boiler temperature.	
tLE	0	Termal Label mode disabled (Functions present with firmware version 4.04).	
HCP	Enter into HCP parameter family and set the following parameters.		
SEr	1	Machine arranged for remote connection to PC.	
6. Switch OFF and then switch ON the machine.			
GEN	Enter into GEN parameter family.		
dIn	90	Initial Detergent Dosage.	
rIn	10	Initial Rinse Aid Dosage.	
dEt	101	Detergent dispenser works when WASH PUMP in activated.	
rA1	61	Rinse Aid dispenser works when LOAD SOLENOID VALVE in activated.	
7. Switch OFF and then switch ON the machine.			

WARNING:

To set the board parameters , carefully follow the order given in this programming file, from point 1 to point 7.

WARNING:

When modifying parameter *dFL* , all the parameters (except those belonging to the *CFG* family) assume the default values according to the tables in section 11 DEFAULT VALUES. The parameters of the *CFG* family are not modified.



ET12AIT

PROG 130

1. Switch OFF and then switch ON the machine.

2. **CFG** Enter into CFG parameter family and set the following parameters:

LYP	0	Hood Type and undercounter.
bo1	0	Atmospheric boiler.
dao	1	Manual Hood.
dFl	1	Default values for Hood Type models.
trc	1	SOFT START enabled.
b.t	1	Tank heater works only if boiler temperature reached.
btf	75	Enable filling tank by means of rinsing cycles.
LES	0	Detergent level switches not enabled.
U1	9	Select user interface hood type/ undercounter model.
rE	0	Regeneration cycle disabled (only for dishwashers with non-continuous water softener).
Alr	1	Alarms enabled.
AAE	0	Boiler electronic level sensor.
FrE	0	Resin regeneration cycle forcing.
SrU	10	Rinse water max. hardness.
bPo	50	Boiler heating control.

3. Switch OFF and then switch ON the machine.

4. Modify Factory parameters:

FAC Enter into FAC parameter family and set the following parameters.

bte	70	Boiler Temperature Threshold.
bH1	96	Boiler temperature: alarm threshold.
BAJ	4	Boiler Temperature Adjust.
bP	1	Boiler standby function enabled.
bSt	2	Booster Function.
btd	0	During stand-by boiler is kept at lower temperature than Temperature Threshold.
teE	63	Tub Temperature: Threshold.
tH1	75	Tank temperature: alarm threshold.

5. Modify the cycle parameters:

CY1 Cycle 1 parameters family.

Ln1	1	Long Wash Phase [min].
Sh1	10	Short Wash Phase [s].
PA1	4	Pause [s].
r11	12	Rinse Phase Duration [s].
dr1	12	Drain [s].
FP1	4	Final Pause [s].

CY2 Cycle 2 parameters family.

Ln2	1	Long Wash Phase [min].
Sh2	40	Short Wash Phase [s].
PA2	4	Pause [s].
r12	12	Rinse Phase Duration [s].
dr2	12	Drain [s].
FP2	4	Final Pause [s].

CY3 Cycle 3 parameters family.

Ln3	1	Long Wash Phase [min].
Sh3	32	Short Wash Phase [s].
PA3	4	Pause [s].
r13	20	Rinse Phase Duration [s].
dr3	20	Drain [s].
FP3	4	Final Pause [s].
bte3	65	Boiler Temperature Threshold for Cycle 3.

**ET12AIT****PROG 130**

drn	Drain parameters family.		
ldr	40	Initial Drain Phase Duration [s].	
fdr	80	Final Drain Phase Duration [s].	
drb	0	Drain and cleaning mode.	
lbd	0	Wash tank water change frequency control disabled.	
dPA	Set other parameters.		
ipa	0	Initial Pause [s] (for ALL cycles).	
dly	3	Delay for the 2 nd wash pump [s].	
pdr	0	Drain Phase Duration at the end of washing phase [s].	
rPA	0	Duration of pause after the rinse cycle [s] (for ALL cycles).	
CF	0	Degrees Celsius display.	
rit	0	During the rinse stage, the display shows the boiler temperature.	
tLE	0	Termal Label mode disabled (Functions present with firmware version 4.04).	
HCP	Enter into HCP parameter family and set the following parameters.		
SEr	1	Machine arranged for remote connection to PC.	
6. Switch OFF and then switch ON the machine.			
GEN	Enter into GEN parameter family.		
dIn	90	Initial Detergent Dosage.	
rIn	10	Initial Rinse Aid Dosage.	
dEt	101	Detergent dispenser works when WASH PUMP in activated.	
rA1	61	Rinse Aid dispenser works when LOAD SOLENOID VALVE in activated.	
7. Switch OFF and then switch ON the machine.			

WARNING:

To set the board parameters , carefully follow the order given in this programming file, from point 1 to point 7.

WARNING:

When modifying parameter *dFL* , all the parameters (except those belonging to the *CFG* family) assume the default values according to the tables in section 11 DEFAULT VALUES. The parameters of the *CFG* family are not modified.



ET5AIIT

PROG 131

1. Switch OFF and then switch ON the machine.

2. **CFG** Enter into CFG parameter family and set the following parameters:

tYP	0	Hood Type and undercounter.
boi	0	Atmospheric boiler.
dao	2	Front loading function.
dFl	3	Default values for Undercounter models.
trc	1	SOFT START enabled.
b.t	0	Boiler heaters and tank heater work simultaneously.
b.tF	75	Enable filling tank by means of rinsing cycles.
LES	0	Detergent level switches not enabled.
U1	0	ACTIVE function disabled.
rE	0	Regeneration cycle disabled.
Alr	1	Alarms enabled.
AAE	0	Boiler electronic level sensor.
FrG	0	Resin regeneration cycle forcing.
SrU	10	Rinse water max. hardness.
bPo	50	Boiler heating control.

3. Switch OFF and then switch ON the machine.

4. Modify Factory parameters:

FAC Enter into FAC parameter family and set the following parameters.

b.tC	82	Boiler Temperature Threshold.
bH1	96	Boiler temperature: alarm threshold.
bAJ	0	Boiler Temperature Adjust.
bP	1	Boiler standby function enabled.
bSt	2	Booster Function.
b.td	3	During stand-by boiler is kept at lower temperature than Temperature Threshold.
t.tC	63	Tub Temperature: Threshold.
t.H1	75	Tank temperature: alarm threshold.

5. Modify the cycle parameters:

CY1 Cycle 1 parameters family.

Ln1	1	Long Wash Phase [min].
Sh1	5	Short Wash Phase [s].
PA1	4	Pause [s].
r.i1	16	Rinse Phase Duration [s].
dr1	30	Drain [s].
FP1	4	Final Pause [s].

CY2 Cycle 2 parameters family.

Ln2	1	Long Wash Phase [min].
Sh2	35	Short Wash Phase [s].
PA2	4	Pause [s].
r.i2	16	Rinse Phase Duration [s].
dr2	30	Drain [s].
FP2	4	Final Pause [s].

CY3 Cycle 3 parameters family.

Ln3	1	Long Wash Phase [min].
Sh3	31	Short Wash Phase [s].
PA3	4	Pause [s].
r.i3	20	Rinse Phase Duration [s].
dr3	40	Drain [s].
FP3	4	Final Pause [s].
b.t3	65	Boiler Temperature Threshold for Cycle 3.

**ET5AIIT****PROG 131**

drn	Drain parameters family.		
idr	30	Initial Drain Phase Duration [s].	
fdr	00	Final Drain Phase Duration [s].	
drt	0	Drain and cleaning mode.	
cbd	0	Wash tank water change frequency control disabled.	
dPA	Set other parameters.		
ipa	5	Initial Pause [s] (for ALL cycles).	
dly	3	Delay for the 2 nd wash pump [s].	
pdr	0	Drain Phase Duration at the end of washing phase [s].	
rPA	0	Duration of pause after the rinse cycle [s] (for ALL cycles).	
CF	0	Degrees Celsius display.	
rit	0	During the rinse stage, the display shows the boiler temperature.	
HCP	Enter into HCP parameter family and set the following parameters.		
SEr	1	Machine arranged for remote connection to PC.	
6. Switch OFF and then switch ON the machine.			
GE_n	Enter into GEn parameter family.		
dIn	50	Initial Detergent Dosage.	
rIn	10	Initial Rinse Aid Dosage.	
dEt	101	Detergent dispenser works when WASH PUMP is activated.	
rA_i	61	Rinse Aid dispenser works when LOAD SOLENOID VALVE is activated.	
7. Switch OFF and then switch ON the machine.			

WARNING:

To set the board parameters, carefully follow the order given in this programming file, from point 1 to point 7.

WARNING:

When modifying parameter **dFL**, all the parameters (except those belonging to the **CFG** family) assume the default values according to the tables in section 11 DEFAULT VALUES. The parameters of the **CFG** family are not modified.



ET5AIDP

PROG 132

1. Switch OFF and then switch ON the machine.

2. **CFG** Enter into CFG parameter family and set the following parameters:

tYP	0	Hood Type and undercounter.
bo i	0	Atmospheric boiler.
dao	2	Front loading function.
dFL	3	Default values for Undercounter models.
trc	1	SOFT START enabled.
b_t	0	Boiler heaters and tank heater work simultaneously.
btF	75	Enable filling tank by means of rinsing cycles.
LES	0	Detergent level switches not enabled.
U i	0	ACTIVE function disabled.
rE	0	Regeneration cycle disabled.
Al r	1	Alarms enabled.
AAQ	1	Boiler float level sensor.
FrG	0	Resin regeneration cycle forcing.
SrU	10	Rinse water max. hardness.
bPo	50	Boiler heating control.

3. Switch OFF and then switch ON the machine.

4. Modify Factory parameters:

FAC Enter into FAC parameter family and set the following parameters.

btT	82	Boiler Temperature Threshold.
bH i	96	Boiler temperature: alarm threshold.
BAJ	0	Boiler Temperature Adjust.
bP	1	Boiler standby function enabled.
bSt	2	Booster Function.
bt d	3	During stand-by boiler is kept at lower temperature than Temperature Threshold.
ttT	63	Tub Temperature: Threshold.
tH i	75	Tank temperature: alarm threshold.

5. Modify the cycle parameters:

CY1 Cycle 1 parameters family.

Ln1	1	Long Wash Phase [min].
Sh1	5	Short Wash Phase [s].
PA1	4	Pause [s].
r i1	16	Rinse Phase Duration [s].
dr1	30	Drain [s].
FP1	4	Final Pause [s].

CY2 Cycle 2 parameters family.

Ln2	1	Long Wash Phase [min].
Sh2	35	Short Wash Phase [s].
PA2	4	Pause [s].
r i2	16	Rinse Phase Duration [s].
dr2	30	Drain [s].
FP2	4	Final Pause [s].

CY3 Cycle 3 parameters family.

Ln3	1	Long Wash Phase [min].
Sh3	31	Short Wash Phase [s].
PA3	4	Pause [s].
r i3	20	Rinse Phase Duration [s].
dr3	40	Drain [s].
FP3	4	Final Pause [s].
bt3	65	Boiler Temperature Threshold for Cycle 3.

**ET5AIDP****PROG 132**

drn	Drain parameters family.		
idr	30	Initial Drain Phase Duration [s].	
fdr	00	Final Drain Phase Duration [s].	
drt	0	Drain and cleaning mode.	
cbd	0	Wash tank water change frequency control disabled.	
dPA	Set other parameters.		
ipa	5	Initial Pause [s] (for ALL cycles).	
dly	3	Delay for the 2 nd wash pump [s].	
pdr	0	Drain Phase Duration at the end of washing phase [s].	
rPA	0	Duration of pause after the rinse cycle [s] (for ALL cycles).	
CF	0	Degrees Celsius display.	
rit	0	During the rinse stage, the display shows the boiler temperature.	
HCP	Enter into HCP parameter family and set the following parameters.		
SEr	9	Dishwasher with incorporated continuous water softener.	
6. Switch OFF and then switch ON the machine.			
GEr	Enter into GEn parameter family.		
dIn	50	Initial Detergent Dosage.	
rIn	10	Initial Rinse Aid Dosage.	
dEt	101	Detergent dispenser works when WASH PUMP is activated.	
rA1	61	Rinse Aid dispenser works when LOAD SOLENOID VALVE is activated.	
7. Switch OFF and then switch ON the machine.			

WARNING:

To set the board parameters, carefully follow the order given in this programming file, from point 1 to point 7.

WARNING:

When modifying parameter **dFL**, all the parameters (except those belonging to the **CFG** family) assume the default values according to the tables in section 11 DEFAULT VALUES. The parameters of the **CFG** family are not modified.



ET5AIDPWS

PROG 133

1. Switch OFF and then switch ON the machine.

2. **CFG** Enter into CFG parameter family and set the following parameters:

tYP	0	Hood Type and undercounter.
bo i	0	Atmospheric boiler.
dao	2	Front loading function.
dFL	3	Default values for Undercounter models.
trc	1	SOFT START enabled.
b_t	1	Tank heater works only if boiler temperature reached.
btF	75	Enable filling tank by means of rinsing cycles.
LES	0	Detergent level switches not enabled.
U i	0	ACTIVE function disabled.
rE	0	Regeneration cycle disabled.
Al r	1	Alarms enabled.
AAQ	1	Boiler float level sensor.
FrG	0	Resin regeneration cycle forcing.
SrU	10	Rinse water max. hardness.
bPo	50	Boiler heating control.

3. Switch OFF and then switch ON the machine.

4. Modify Factory parameters:

FAC Enter into FAC parameter family and set the following parameters.

btT	82	Boiler Temperature Threshold.
bH i	96	Boiler temperature: alarm threshold.
BAJ	0	Boiler Temperature Adjust.
bP	1	Boiler standby function enabled.
bSt	2	Booster Function.
bt d	3	During stand-by boiler is kept at lower temperature than Temperature Threshold.
ttT	63	Tub Temperature: Threshold.
tH i	75	Tank temperature: alarm threshold.

5. Modify the cycle parameters:

CY1 Cycle 1 parameters family.

Ln1	1	Long Wash Phase [min].
Sh1	5	Short Wash Phase [s].
PA1	4	Pause [s].
r i1	16	Rinse Phase Duration [s].
dr1	30	Drain [s].
FP1	4	Final Pause [s].

CY2 Cycle 2 parameters family.

Ln2	1	Long Wash Phase [min].
Sh2	35	Short Wash Phase [s].
PA2	4	Pause [s].
r i2	16	Rinse Phase Duration [s].
dr2	30	Drain [s].
FP2	4	Final Pause [s].

CY3 Cycle 3 parameters family.

Ln3	1	Long Wash Phase [min].
Sh3	31	Short Wash Phase [s].
PA3	4	Pause [s].
r i3	20	Rinse Phase Duration [s].
dr3	40	Drain [s].
FP3	4	Final Pause [s].
bt3	65	Boiler Temperature Threshold for Cycle 3.

**ET5AIDPWS****PROG 133**

drn	Drain parameters family.		
idr	30	Initial Drain Phase Duration [s].	
fdr	00	Final Drain Phase Duration [s].	
drt	0	Drain and cleaning mode.	
cbd	0	Wash tank water change frequency control disabled.	
dPA	Set other parameters.		
ipa	5	Initial Pause [s] (for ALL cycles).	
dly	3	Delay for the 2 nd wash pump [s].	
pdr	0	Drain Phase Duration at the end of washing phase [s].	
rPA	0	Duration of pause after the rinse cycle [s] (for ALL cycles).	
CF	0	Degrees Celsius display.	
rit	0	During the rinse stage, the display shows the boiler temperature.	
HCP	Enter into HCP parameter family and set the following parameters.		
SEr	9	Dishwasher with incorporated continuous water softener.	
6. Switch OFF and then switch ON the machine.			
GEr	Enter into GEn parameter family.		
dIn	50	Initial Detergent Dosage.	
rIn	10	Initial Rinse Aid Dosage.	
dEt	101	Detergent dispenser works when WASH PUMP is activated.	
rA1	61	Rinse Aid dispenser works when LOAD SOLENOID VALVE is activated.	
7. Switch OFF and then switch ON the machine.			

WARNING:

To set the board parameters, carefully follow the order given in this programming file, from point 1 to point 7.

WARNING:

When modifying parameter **dFL**, all the parameters (except those belonging to the **CFG** family) assume the default values according to the tables in section 11 DEFAULT VALUES. The parameters of the **CFG** family are not modified.

**ZUCADDROW / EUCADDROW PROG 134**

1. Switch OFF and then switch ON the machine.

2. **CFG** Enter into CFG parameter family and set the following parameters:

tYP	0	Hood Type and undercounter.
boi	0	Atmospheric boiler.
dao	2	Front loading function.
dFL	3	Default values for Undercounter models.
trc	1	SOFT START enabled.
b.t	1	Tank heater works only if boiler temperature reached.
btf	75	Enable filling tank by means of rinsing cycles.
LES	0	Detergent level switches not enabled.
U1	9	Select user interface hood type/ undercounter model.
rE	0	Regeneration cycle disabled.
Alr	0	Alarms not enabled.
AAE	0	Boiler electronic level sensor.
FrE	0	Resin regeneration cycle forcing.
SrU	10	Rinse water max. hardness.
bPo	50	Boiler heating control.

3. Switch OFF and then switch ON the machine.

4. Modify Factory parameters:

FAC Enter into FAC parameter family and set the following parameters.

bte	84	Boiler Temperature Threshold.
bH1	96	Boiler temperature: alarm threshold.
BAJ	0	Boiler Temperature Adjust.
bP	1	Boiler standby function enabled.
bSt	2	Booster Function.
btd	3	During stand-by boiler is kept at lower temperature than Temperature Threshold.
teE	73	Tub Temperature: Threshold.
teH	2	Tub Temperature: HISTERESIS.
tH1	80	Tank temperature: alarm threshold.

5. Modify the cycle parameters:

CY1 Cycle 1 parameters family.

Ln1	0	Long Wash Phase [min].
Sh1	57	Short Wash Phase [s].
PA1	4	Pause [s].
r11	12	Rinse Phase Duration [s].
dr1	25	Drain [s].
FP1	2	Final Pause [s].

CY2 Cycle 2 parameters family.

Ln2	2	Long Wash Phase [min].
Sh2	42	Short Wash Phase [s].
PA2	4	Pause [s].
r12	12	Rinse Phase Duration [s].
dr2	25	Drain [s].
FP2	2	Final Pause [s].

CY3 Cycle 3 parameters family.

Ln3	1	Long Wash Phase [min].
Sh3	42	Short Wash Phase [s].
PA3	4	Pause [s].
r13	12	Rinse Phase Duration [s].
dr3	25	Drain [s].
FP3	2	Final Pause [s].
bte3	65	Boiler Temperature Threshold for Cycle 3.

**ZUCADDROW / EUCADDROW PROG 134**

drn	Drain parameters family.	
idr	30	Initial Drain Phase Duration [s].
fdr	100	Final Drain Phase Duration [s].
drt	0	Drain and cleaning mode.
cbd	0	Wash tank water change frequency control disabled.
dPA	Set other parameters.	
ipa	0	Initial Pause [s] (for ALL cycles).
dly	3	Delay for the 2 nd wash pump [s].
pdr	0	Drain Phase Duration at the end of washing phase [s].
rPA	0	Duration of pause after the rinse cycle [s] (for ALL cycles).
CF	0	Degrees Celsius display.
rit	0	During the rinse stage, the display shows the boiler temperature.
HCP	Enter into HCP parameter family and set the following parameters.	
SEr	1	Machine arranged for remote connection to PC.
6. Switch OFF and then switch ON the machine.		
GE_n	Enter into GEn parameter family.	
dIn	50	Initial Detergent Dosage.
rIn	10	Initial Rinse Aid Dosage.
dEt	6	Detergent dispensing during the wash cycle (loading during wash stage).
rA_i	4	Rinse aid dispensing during the rinse cycle (loading during boiler filling stage).
7. Switch OFF and then switch ON the machine.		

WARNING:

To set the board parameters , carefully follow the order given in this programming file, from point 1 to point 7.

WARNING:

When modifying parameter *dFL* , all the parameters (except those belonging to the *CFG* family) assume the default values according to the tables in section 11 DEFAULT VALUES. The parameters of the *CFG* family are not modified.



FUCA3DD

PROG 135

1. Switch OFF and then switch ON the machine.

2. **CFG** Enter into CFG parameter family and set the following parameters:

LYP	0	Hood Type and undercounter.
boi	0	Atmospheric boiler.
dao	2	Front loading function.
dFl	3	Default values for Undercounter models.
trc	1	SOFT START enabled.
b.t	1	Tank heater works only if boiler temperature reached.
btf	75	Enable filling tank by means of rinsing cycles.
LES	0	Detergent level switches not enabled.
U1	24	Select user interface for LS5.
rE	0	Regeneration cycle disabled.
Alr	0	Alarms not enabled.
AAE	0	Boiler electronic level sensor.
FrG	0	Resin regeneration cycle forcing.
SrU	10	Rinse water max. hardness.
bPo	50	Boiler heating control.

3. Switch OFF and then switch ON the machine.

4. Modify Factory parameters:

FAC Enter into FAC parameter family and set the following parameters.

bte	80	Boiler Temperature Threshold.
bH1	96	Boiler temperature: alarm threshold.
BAJ	0	Boiler Temperature Adjust.
bP	1	Boiler standby function enabled.
bSt	2	Booster Function.
btd	3	During stand-by boiler is kept at lower temperature than Temperature Threshold.
teE	63	Tub Temperature: Threshold.
tH1	75	Tank temperature: alarm threshold.

5. Modify the cycle parameters:

Y1 Cycle 1 parameters family.

Ln1	1	Long Wash Phase [min].
Sh1	42	Short Wash Phase [s].
PA1	4	Pause [s].
ri1	12	Rinse Phase Duration [s].
dr1	30	Drain [s].
FP1	2	Final Pause [s].

Y2 Cycle 2 parameters family.

Ln2	2	Long Wash Phase [min].
Sh2	42	Short Wash Phase [s].
PA2	4	Pause [s].
ri2	12	Rinse Phase Duration [s].
dr2	30	Drain [s].
FP2	2	Final Pause [s].

Y3 Cycle 3 parameters family.

Ln3	2	Long Wash Phase [min].
Sh3	42	Short Wash Phase [s].
PA3	4	Pause [s].
ri3	12	Rinse Phase Duration [s].
dr3	30	Drain [s].
FP3	2	Final Pause [s].
bte3	0	Boiler Temperature Threshold for Cycle 3.

**FUCA3DD****PROG 135**

drn	Drain parameters family.		
idr	30	Initial Drain Phase Duration [s].	
Fdr	100	Final Drain Phase Duration [s].	
drt	0	Drain and cleaning mode.	
cbd	0	Wash tank water change frequency control disabled.	
dPA	Set other parameters.		
IPA	0	Initial Pause [s] (for ALL cycles).	
dLY	3	Delay for the 2 nd wash pump [s].	
Pdr	0	Drain Phase Duration at the end of washing phase [s].	
rPA	0	Duration of pause after the rinse cycle [s] (for ALL cycles).	
CF	0	Degrees Celsius display.	
rit	0	During the rinse stage, the display shows the boiler temperature.	
HCP	Enter into HCP parameter family and set the following parameters.		
SEr	1	Machine arranged for remote connection to PC.	
6. Switch OFF and then switch ON the machine.			
GEN	Enter into GEN parameter family.		
dIn	50	Initial Detergent Dosage.	
rIn	10	Initial Rinse Aid Dosage.	
dEt	6	Detergent dispensing during the wash cycle (loading during wash stage).	
rA,	4	Rinse aid dispensing during the rinse cycle (loading during boiler filling stage).	
7. Switch OFF and then switch ON the machine.			

WARNING:

To set the board parameters , carefully follow the order given in this programming file, from point 1 to point 7.

WARNING:

When modifying parameter *dFL* , all the parameters (except those belonging to the *CFG* family) assume the default values according to the tables in section 11 DEFAULT VALUES. The parameters of the *CFG* family are not modified.



NUCA1DDG / NUC1GRUK		PROG 136
1. Switch OFF and then switch ON the machine.		
2. CFG Enter into CFG parameter family and set the following parameters:		
	LYP	0 Hood Type and undercounter.
	boi	0 Atmospheric boiler.
	dao	2 Front loading function.
	dFl	3 Default values for Undercounter models.
	trc	1 SOFT START enabled.
	b.t	1 Tank heater works only if boiler temperature reached.
	btf	75 Enable filling tank by means of rinsing cycles.
	LES	0 Detergent level switches not enabled.
	U1	24 Select user interface for LS5.
	rE	0 Regeneration cycle disabled.
	Alr	0 Alarms not enabled.
	AAE	0 Boiler electronic level sensor.
	FrG	0 Resin regeneration cycle forcing.
	SrU	10 Rinse water max. hardness.
	bPo	50 Boiler heating control.
3. Switch OFF and then switch ON the machine.		
4. Modify Factory parameters:		
FAC Enter into FAC parameter family and set the following parameters.		
	bte	80 Boiler Temperature Threshold.
	bH1	96 Boiler temperature: alarm threshold.
	BAJ	0 Boiler Temperature Adjust.
	bP	1 Boiler standby function enabled.
	bSt	2 Booster Function.
	btd	3 During stand-by boiler is kept at lower temperature than Temperature Threshold.
	teE	63 Tub Temperature: Threshold.
	tH1	75 Tank temperature: alarm threshold.
5. Modify the cycle parameters:		
CY1 Cycle 1 parameters family.		
	Ln1	1 Long Wash Phase [min].
	Sh1	12 Short Wash Phase [s].
	PA1	4 Pause [s].
	ri1	12 Rinse Phase Duration [s].
	dr1	25 Drain [s].
	FP1	2 Final Pause [s].
CY2 Cycle 2 parameters family.		
	Ln2	2 Long Wash Phase [min].
	Sh2	42 Short Wash Phase [s].
	PA2	4 Pause [s].
	ri2	12 Rinse Phase Duration [s].
	dr2	30 Drain [s].
	FP2	2 Final Pause [s].
CY3 Cycle 3 parameters family.		
	Ln3	2 Long Wash Phase [min].
	Sh3	42 Short Wash Phase [s].
	PA3	4 Pause [s].
	ri3	12 Rinse Phase Duration [s].
	dr3	30 Drain [s].
	FP3	2 Final Pause [s].
	bte3	0 Boiler Temperature Threshold for Cycle 3.

**NUCA1DDG / NUC1GRUK****PROG 136**

drn	Drain parameters family.		
idr	30	Initial Drain Phase Duration [s].	
fdr	100	Final Drain Phase Duration [s].	
drt	0	Drain and cleaning mode.	
cbd	0	Wash tank water change frequency control disabled.	
dPA	Set other parameters.		
ipa	0	Initial Pause [s] (for ALL cycles).	
dly	3	Delay for the 2 nd wash pump [s].	
pdr	0	Drain Phase Duration at the end of washing phase [s].	
rPA	0	Duration of pause after the rinse cycle [s] (for ALL cycles).	
CF	0	Degrees Celsius display.	
rit	0	During the rinse stage, the display shows the boiler temperature.	
HCP	Enter into HCP parameter family and set the following parameters.		
SEr	1	Machine arranged for remote connection to PC.	
6. Switch OFF and then switch ON the machine.			
GE_n	Enter into GEn parameter family.		
dIn	50	Initial Detergent Dosage.	
rIn	10	Initial Rinse Aid Dosage.	
dEt	6	Detergent dispensing during the wash cycle (loading during wash stage).	
rA_i	4	Rinse aid dispensing during the rinse cycle (loading during boiler filling stage).	
7. Switch OFF and then switch ON the machine.			

WARNING:

To set the board parameters , carefully follow the order given in this programming file, from point 1 to point 7.

WARNING:

When modifying parameter **dFL** , all the parameters (except those belonging to the **CFG** family) assume the default values according to the tables in section 11 DEFAULT VALUES. The parameters of the **CFG** family are not modified.



NUC1GMS

PROG 137

1. Switch OFF and then switch ON the machine.

2. **CFG** Enter into CFG parameter family and set the following parameters:

tYP	0	Hood Type and undercounter.
boi	1	Pressure boiler.
dao	2	Front loading function.
dFl	3	Default values for Undercounter models.
trc	0	Disabled (for this appliance SOFT START is NOT possible).
b.t	1	Tank heater works only if boiler temperature reached.
b.tF	0	The tank is filled into the traditional way.
LES	0	Detergent level switches not enabled.
U1	24	Select user interface for LS5.
rE	0	Regeneration cycle disabled.
Alr	0	Alarms not enabled.
AAE	0	Boiler electronic level sensor.
FrG	0	Resin regeneration cycle forcing.
SrU	10	Rinse water max. hardness.
bPo	50	Boiler heating control.

3. Switch OFF and then switch ON the machine.

4. Modify Factory parameters:

FAC Enter into FAC parameter family and set the following parameters.

b.tC	82	Boiler Temperature Threshold.
bH1	96	Boiler temperature: alarm threshold.
bAJ	3	Boiler Temperature Adjust.
bP	1	Boiler standby function enabled.
bSt	2	Booster Function.
b.td	3	During stand-by boiler is kept at lower temperature than Temperature Threshold.
t.tC	63	Tub Temperature: Threshold.
t.H1	75	Tank temperature: alarm threshold.

5. Modify the cycle parameters:

CY1 Cycle 1 parameters family.

Ln1	1	Long Wash Phase [min].
Sh1	12	Short Wash Phase [s].
PA1	4	Pause [s].
r.i1	14	Rinse Phase Duration [s].
dr1	30	Drain [s].
FP1	0	Final Pause [s].

CY2 Cycle 2 parameters family.

Ln2	2	Long Wash Phase [min].
Sh2	40	Short Wash Phase [s].
PA2	4	Pause [s].
r.i2	16	Rinse Phase Duration [s].
dr2	30	Drain [s].
FP2	0	Final Pause [s].

CY3 Cycle 3 parameters family.

Ln3	2	Long Wash Phase [min].
Sh3	40	Short Wash Phase [s].
PA3	4	Pause [s].
r.i3	16	Rinse Phase Duration [s].
dr3	30	Drain [s].
FP3	0	Final Pause [s].
b.t3	0	Boiler Temperature Threshold for Cycle 3.

**NUC1GMS****PROG 137**

drn	Drain parameters family.		
idr	30	Initial Drain Phase Duration [s].	
Fdr	100	Final Drain Phase Duration [s].	
drt	0	Drain and cleaning mode.	
cbd	0	Wash tank water change frequency control disabled.	
dPA	Set other parameters.		
IPA	0	Initial Pause [s] (for ALL cycles).	
dLY	3	Delay for the 2 nd wash pump [s].	
Pdr	0	Drain Phase Duration at the end of washing phase [s].	
rPA	0	Duration of pause after the rinse cycle [s] (for ALL cycles).	
CF	0	Degrees Celsius display.	
rit	0	During the rinse stage, the display shows the boiler temperature.	
HCP	Enter into HCP parameter family and set the following parameters.		
SEr	1	Machine arranged for remote connection to PC.	
6. Switch OFF and then switch ON the machine.			
GEr	Enter into GEn parameter family.		
dIn	165	Initial Detergent Dosage.	
rIn	0	Initial Rinse Aid Dosage.	
dEt	182	Detergent dispenser works when LOAD SOLENOID VALVE in activated.	
rA i	61	Rinse Aid dispenser works when LOAD SOLENOID VALVE in activated.	
7. Switch OFF and then switch ON the machine.			

WARNING:

To set the board parameters , carefully follow the order given in this programming file, from point 1 to point 7.

WARNING:

When modifying parameter **dFL** , all the parameters (except those belonging to the **CFG** family) assume the default values according to the tables in section 11 DEFAULT VALUES. The parameters of the **CFG** family are not modified.

**NUC3 / KUC3 / EUC3****PROG 138**

1. Switch OFF and then switch ON the machine.

2. **CFG** Enter into CFG parameter family and set the following parameters:

tYP	0	Hood Type and undercounter.
bo i	1	Pressure boiler.
doo	2	Front loading function.
dFl	3	Default values for Undercounter models.
trc	1	SOFT START enabled.
b.t	1	Tank heater works only if boiler temperature reached.
b.tF	0	The tank is filled into the traditional way.
LES	0	Detergent level switches not enabled.
U1	24	Select user interface for LS5.
rE	0	Regeneration cycle disabled.
Al r	0	Alarms not enabled.
RAE	0	Boiler electronic level sensor.
FrG	0	Resin regeneration cycle forcing.
SrU	10	Rinse water max. hardness.
bPo	50	Boiler heating control.

3. Switch OFF and then switch ON the machine.

4. Modify Factory parameters:

FAC Enter into FAC parameter family and set the following parameters.

b.tC	84	Boiler Temperature Threshold.
bH i	96	Boiler temperature: alarm threshold.
bAJ	3	Boiler Temperature Adjust.
bP	1	Boiler standby function enabled.
bSt	2	Booster Function.
b.td	3	During stand-by boiler is kept at lower temperature than Temperature Threshold.
t.tC	63	Tub Temperature: Threshold.
t.H i	75	Tank temperature: alarm threshold.

5. Modify the cycle parameters:

CY1 Cycle 1 parameters family.

Ln1	1	Long Wash Phase [min].
Sh1	40	Short Wash Phase [s].
PA1	4	Pause [s].
r i1	16	Rinse Phase Duration [s].
dr1	30	Drain [s].
FP1	0	Final Pause [s].

CY2 Cycle 2 parameters family.

Ln2	2	Long Wash Phase [min].
Sh2	40	Short Wash Phase [s].
PA2	4	Pause [s].
r i2	16	Rinse Phase Duration [s].
dr2	30	Drain [s].
FP2	0	Final Pause [s].

CY3 Cycle 3 parameters family.

Ln3	2	Long Wash Phase [min].
Sh3	40	Short Wash Phase [s].
PA3	4	Pause [s].
r i3	16	Rinse Phase Duration [s].
dr3	30	Drain [s].
FP3	0	Final Pause [s].
b.t3	0	Boiler Temperature Threshold for Cycle 3.

**NUC3 / KUC3 / EUC3****PROG 138**

drn	Drain parameters family.	
idr	30	Initial Drain Phase Duration [s].
Fdr	100	Final Drain Phase Duration [s].
drb	0	Drain and cleaning mode.
cbd	40	Number of wash cycles possible between one drain cycle and the next.
dPA	Set other parameters.	
IPA	0	Initial Pause [s] (for ALL cycles).
dLY	3	Delay for the 2 nd wash pump [s].
Pdr	0	Drain Phase Duration at the end of washing phase [s].
rPA	0	Duration of pause after the rinse cycle [s] (for ALL cycles).
CF	0	Degrees Celsius display.
rit	0	During the rinse stage, the display shows the boiler temperature.
HCP	Enter into HCP parameter family and set the following parameters.	
SEr	1	Machine arranged for remote connection to PC.
6. Switch OFF and then switch ON the machine.		
GEr	Enter into GEn parameter family.	
dIn	165	Initial Detergent Dosage.
rIn	0	Initial Rinse Aid Dosage.
dEt	182	Detergent dispenser works when LOAD SOLENOID VALVE in activated.
rA i	61	Rinse Aid dispenser works when LOAD SOLENOID VALVE in activated.
7. Switch OFF and then switch ON the machine.		

WARNING:

To set the board parameters , carefully follow the order given in this programming file, from point 1 to point 7.

WARNING:

When modifying parameter **dFL** , all the parameters (except those belonging to the **CFG** family) assume the default values according to the tables in section 11 DEFAULT VALUES. The parameters of the **CFG** family are not modified.

**ZPPW / APPW / EPPW (EX PW1 / PW1H) PROG 139**

1. Switch OFF and then switch ON the machine.

2. **CFG** Enter into CFG parameter family and set the following parameters:

LYP	1	Pot Washer.
bo1	0	Atmospheric boiler.
dao	2	Front loading function.
dFL	2	Default values for Pot Washer models.
trc	0	Disabled (for this appliance SOFT START is NOT possible).
b.t	1	Tank heater works only if boiler temperature reached.
btf	0	The tank is filled into the traditional way.
LES	0	Detergent level switches not enabled.
U1	9	Select user interface hood type/ undercounter model.
rE	0	Regeneration cycle disabled (only for dishwashers with non-continuous water softener).
Alr	1	Alarms enabled.
AAE	0	Boiler electronic level sensor.
FrE	0	Resin regeneration cycle forcing.
SrU	10	Rinse water max. hardness.
bPo	50	Boiler heating control.

3. Switch OFF and then switch ON the machine.

4. Modify Factory parameters:

FAC Enter into FAC parameter family and set the following parameters.

bte	70	Boiler Temperature Threshold.
bH1	96	Boiler temperature: alarm threshold.
BAJ	4	Boiler Temperature Adjust.
bP	1	Boiler standby function enabled.
bSt	4	Booster Function.
btd	0	During stand-by boiler is kept at lower temperature than Temperature Threshold.
teE	63	Tub Temperature: Threshold.
tH1	75	Tank temperature: alarm threshold.

5. Modify the cycle parameters:

CY1 Cycle 1 parameters family.

Ln1	2	Long Wash Phase [min].
Sh1	34	Short Wash Phase [s].
PA1	4	Pause [s].
ri1	20	Rinse Phase Duration [s].
dr1	12	Drain [s].
FP1	0	Final Pause [s].

CY2 Cycle 2 parameters family.

Ln2	5	Long Wash Phase [min].
Sh2	34	Short Wash Phase [s].
PA2	4	Pause [s].
ri2	20	Rinse Phase Duration [s].
dr2	12	Drain [s].
FP2	0	Final Pause [s].

CY3 Cycle 3 parameters family.

Ln3	8	Long Wash Phase [min].
Sh3	34	Short Wash Phase [s].
PA3	4	Pause [s].
ri3	20	Rinse Phase Duration [s].
dr3	12	Drain [s].
FP3	0	Final Pause [s].
bte3	0	Boiler Temperature Threshold for Cycle 3.

**ZPPW / APPW / EPPW (EX PW1 / PW1H) PROG 139**

drn	Drain parameters family.	
ldr	120	Initial Drain Phase Duration [s].
fdr	90	Final Drain Phase Duration [s].
drt	0	Drain and cleaning mode.
lbd	0	Wash tank water change frequency control disabled.
dto	48	Drain cycle Timeout.
dPA	Set other parameters.	
ipa	2	Initial Pause [s] (for ALL cycles).
dly	3	Delay for the 2 nd wash pump [s].
pdr	0	Drain Phase Duration at the end of washing phase [s].
rpa	0	Duration of pause after the rinse cycle [s] (for ALL cycles).
cf	0	Degrees Celsius display.
rit	0	During the rinse stage, the display shows the boiler temperature.
tle	0	Thermal Label mode disabled (Functions present with firmware version 4.04).
HCP	Enter into HCP parameter family and set the following parameters.	
ser	1	Machine arranged for remote connection to PC.
6. Switch OFF and then switch ON the machine.		
GEN	Enter into GEN parameter family.	
dln	240	Initial Detergent Dosage.
rln	18	Initial Rinse Aid Dosage.
dEt	16	Detergent dispensing during the wash cycle (loading during wash stage).
ra1	7	Rinse aid dispensing during the rinse cycle (loading during boiler filling stage).
7. Switch OFF and then switch ON the machine.		

WARNING:

To set the board parameters , carefully follow the order given in this programming file, from point 1 to point 7.

WARNING:

When modifying parameter **dFL**, all the parameters (except those belonging to the **CFG** family) assume the default values according to the tables in section 11 DEFAULT VALUES. The parameters of the **CFG** family are not modified.

**ZPPW / APPW / EPPW (EX PW2)****PROG 140**

1. Switch OFF and then switch ON the machine.

2. **CFG** Enter into CFG parameter family and set the following parameters:

LYP	1	Pot Washer.
bo1	0	Atmospheric boiler.
dao	2	Front loading function.
dFL	2	Default values for Pot Washer models.
trc	0	Disabled (for this appliance SOFT START is NOT possible).
b.t	1	Tank heater works only if boiler temperature reached.
btf	0	The tank is filled into the traditional way.
LES	0	Detergent level switches not enabled.
U1	9	Select user interface hood type/ undercounter model.
rE	0	Regeneration cycle disabled (only for dishwashers with non-continuous water softener).
Alr	1	Alarms enabled.
AAE	0	Boiler electronic level sensor.
FrE	0	Resin regeneration cycle forcing.
SrU	10	Rinse water max. hardness.
bPo	50	Boiler heating control.

3. Switch OFF and then switch ON the machine.

4. Modify Factory parameters:

FAC Enter into FAC parameter family and set the following parameters.

bte	70	Boiler Temperature Threshold.
bH1	96	Boiler temperature: alarm threshold.
BAJ	4	Boiler Temperature Adjust.
bP	1	Boiler standby function enabled.
bSt	4	Booster Function.
btd	0	During stand-by boiler is kept at lower temperature than Temperature Threshold.
teE	63	Tub Temperature: Threshold.
tH1	75	Tank temperature: alarm threshold.

5. Modify the cycle parameters:

LY1 Cycle 1 parameters family.

Ln1	2	Long Wash Phase [min].
Sh1	34	Short Wash Phase [s].
PA1	4	Pause [s].
r11	20	Rinse Phase Duration [s].
dr1	21	Drain [s].
FP1	0	Final Pause [s].

LY2 Cycle 2 parameters family.

Ln2	5	Long Wash Phase [min].
Sh2	34	Short Wash Phase [s].
PA2	4	Pause [s].
r12	20	Rinse Phase Duration [s].
dr2	21	Drain [s].
FP2	0	Final Pause [s].

LY3 Cycle 3 parameters family.

Ln3	8	Long Wash Phase [min].
Sh3	34	Short Wash Phase [s].
PA3	4	Pause [s].
r13	20	Rinse Phase Duration [s].
dr3	21	Drain [s].
FP3	0	Final Pause [s].
bte3	0	Boiler Temperature Threshold for Cycle 3.

**ZPPW / APPW / EPPW (EX PW2)****PROG 140**

drn	Drain parameters family.	
ldr	180	Initial Drain Phase Duration [s].
fdr	90	Final Drain Phase Duration [s].
drt	0	Drain and cleaning mode.
cbd	0	Wash tank water change frequency control disabled.
dto	48	Drain cycle Timeout.
dPA	Set other parameters.	
ipa	2	Initial Pause [s] (for ALL cycles).
dly	3	Delay for the 2 nd wash pump [s].
pdr	0	Drain Phase Duration at the end of washing phase [s].
rPA	0	Duration of pause after the rinse cycle [s] (for ALL cycles).
CF	0	Degrees Celsius display.
rit	0	During the rinse stage, the display shows the boiler temperature.
tLE	0	Thermal Label mode disabled (Functions present with firmware version 4.04).
HCP	Enter into HCP parameter family and set the following parameters.	
SEr	1	Machine arranged for remote connection to PC.
6. Switch OFF and then switch ON the machine.		
GE_n	Enter into GEn parameter family.	
dIn	240	Initial Detergent Dosage.
rIn	18	Initial Rinse Aid Dosage.
dEt	16	Detergent dispensing during the wash cycle (loading during wash stage).
rA_i	7	Rinse aid dispensing during the rinse cycle (loading during boiler filling stage).
7. Switch OFF and then switch ON the machine.		

WARNING:

To set the board parameters , carefully follow the order given in this programming file, from point 1 to point 7.

WARNING:

When modifying parameter **dFL** , all the parameters (except those belonging to the **CFG** family) assume the default values according to the tables in section 11 DEFAULT VALUES. The parameters of the **CFG** family are not modified.

**EPPWESG60 (EX PW1 - 60Hz)****PROG 141**

1. Switch OFF and then switch ON the machine.

2. **CFG** Enter into CFG parameter family and set the following parameters:

LYP	1	Pot Washer.
bo1	0	Atmospheric boiler.
dao	2	Front loading function.
dFL	2	Default values for Pot Washer models.
trc	0	Disabled (for this appliance SOFT START is NOT possible).
b.t	1	Tank heater works only if boiler temperature reached.
btf	0	The tank is filled into the traditional way.
LES	0	Detergent level switches not enabled.
U1	9	Select user interface hood type/ undercounter model.
rE	0	Regeneration cycle disabled (only for dishwashers with non-continuous water softener).
Alr	1	Alarms enabled.
RAE	0	Boiler electronic level sensor.
FrG	0	Resin regeneration cycle forcing.
SrU	10	Rinse water max. hardness.
bPo	50	Boiler heating control.

3. Switch OFF and then switch ON the machine.

4. Modify Factory parameters:

FAC Enter into FAC parameter family and set the following parameters.

bte	70	Boiler Temperature Threshold.
bH1	96	Boiler temperature: alarm threshold.
BAJ	4	Boiler Temperature Adjust.
bP	1	Boiler standby function enabled.
bSt	4	Booster Function.
btd	0	During stand-by boiler is kept at lower temperature than Temperature Threshold.
te	63	Tub Temperature: Threshold.
tH1	75	Tank temperature: alarm threshold.

5. Modify the cycle parameters:

CY1 Cycle 1 parameters family.

Ln1	2	Long Wash Phase [min].
Sh1	34	Short Wash Phase [s].
PA1	4	Pause [s].
r1	20	Rinse Phase Duration [s].
dr1	13	Drain [s].
FP1	0	Final Pause [s].

CY2 Cycle 2 parameters family.

Ln2	5	Long Wash Phase [min].
Sh2	34	Short Wash Phase [s].
PA2	4	Pause [s].
r2	20	Rinse Phase Duration [s].
dr2	13	Drain [s].
FP2	0	Final Pause [s].

CY3 Cycle 3 parameters family.

Ln3	8	Long Wash Phase [min].
Sh3	34	Short Wash Phase [s].
PA3	4	Pause [s].
r3	20	Rinse Phase Duration [s].
dr3	13	Drain [s].
FP3	0	Final Pause [s].
bte3	0	Boiler Temperature Threshold for Cycle 3.

**EPPWESG60 (EX PW1 - 60Hz)****PROG 141**

drn	Drain parameters family.	
ldr	120	Initial Drain Phase Duration [s].
fdr	120	Final Drain Phase Duration [s].
drt	0	Drain and cleaning mode.
lbd	0	Wash tank water change frequency control disabled.
dto	48	Drain cycle Timeout.
dPA	Set other parameters.	
ipa	2	Initial Pause [s] (for ALL cycles).
dly	3	Delay for the 2 nd wash pump [s].
pdr	0	Drain Phase Duration at the end of washing phase [s].
rPA	0	Duration of pause after the rinse cycle [s] (for ALL cycles).
CF	0	Degrees Celsius display.
rit	0	During the rinse stage, the display shows the boiler temperature.
tLE	0	Termal Label mode disabled (Functions present with firmware version 4.04).
HCP	Enter into HCP parameter family and set the following parameters.	
SEr	1	Machine arranged for remote connection to PC.
6. Switch OFF and then switch ON the machine.		
GEN	Enter into GEN parameter family.	
dIn	240	Initial Detergent Dosage.
rIn	18	Initial Rinse Aid Dosage.
dEt	16	Detergent dispensing during the wash cycle (loading during wash stage).
rA1	7	Rinse aid dispensing during the rinse cycle (loading during boiler filling stage).
7. Switch OFF and then switch ON the machine.		

WARNING:

To set the board parameters , carefully follow the order given in this programming file, from point 1 to point 7.

WARNING:

When modifying parameter **dFL** , all the parameters (except those belonging to the **CFG** family) assume the default values according to the tables in section 11 DEFAULT VALUES. The parameters of the **CFG** family are not modified.

**EPPWELG60 (EX PW2 - 60Hz)****PROG 142**

1. Switch OFF and then switch ON the machine.

2. **CFG** Enter into CFG parameter family and set the following parameters:

tYP	1	Pot Washer.
bo1	0	Atmospheric boiler.
do0	2	Front loading function.
dFL	2	Default values for Pot Washer models.
trc	0	Disabled (for this appliance SOFT START is NOT possible).
b.t	1	Tank heater works only if boiler temperature reached.
b.tF	0	The tank is filled into the traditional way.
LES	0	Detergent level switches not enabled.
U1	9	Select user interface hood type/ undercounter model.
rE	0	Regeneration cycle disabled (only for dishwashers with non-continuous water softener).
Alr	1	Alarms enabled.
RAE	0	Boiler electronic level sensor.
FrG	0	Resin regeneration cycle forcing.
SrU	10	Rinse water max. hardness.
bPo	50	Boiler heating control.

3. Switch OFF and then switch ON the machine.

4. Modify Factory parameters:

FAC Enter into FAC parameter family and set the following parameters.

b.tC	70	Boiler Temperature Threshold.
b.H1	96	Boiler temperature: alarm threshold.
bAJ	4	Boiler Temperature Adjust.
bP	1	Boiler standby function enabled.
bSt	4	Booster Function.
b.td	0	During stand-by boiler is kept at lower temperature than Temperature Threshold.
t.tC	63	Tub Temperature: Threshold.
t.H1	75	Tank temperature: alarm threshold.

5. Modify the cycle parameters:

CY1 Cycle 1 parameters family.

Ln1	2	Long Wash Phase [min].
Sh1	34	Short Wash Phase [s].
PA1	4	Pause [s].
r.i1	20	Rinse Phase Duration [s].
dr1	22	Drain [s].
FP1	0	Final Pause [s].

CY2 Cycle 2 parameters family.

Ln2	5	Long Wash Phase [min].
Sh2	34	Short Wash Phase [s].
PA2	4	Pause [s].
r.i2	20	Rinse Phase Duration [s].
dr2	22	Drain [s].
FP2	0	Final Pause [s].

CY3 Cycle 3 parameters family.

Ln3	0	Long Wash Phase [min].
Sh3	34	Short Wash Phase [s].
PA3	4	Pause [s].
r.i3	20	Rinse Phase Duration [s].
dr3	22	Drain [s].
FP3	0	Final Pause [s].
b.t3	0	Boiler Temperature Threshold for Cycle 3.

**EPPWELG60 (EX PW2 - 60Hz)****PROG 142**

drn	Drain parameters family.	
ldr	180	Initial Drain Phase Duration [s].
fdr	140	Final Drain Phase Duration [s].
drt	0	Drain and cleaning mode.
cbd	0	Wash tank water change frequency control disabled.
dto	48	Drain cycle Timeout.
dPA	Set other parameters.	
ipa	2	Initial Pause [s] (for ALL cycles).
dly	3	Delay for the 2 nd wash pump [s].
pdr	0	Drain Phase Duration at the end of washing phase [s].
rPA	0	Duration of pause after the rinse cycle [s] (for ALL cycles).
CF	0	Degrees Celsius display.
rit	0	During the rinse stage, the display shows the boiler temperature.
tLE	0	Termal Label mode disabled (Functions present with firmware version 4.04).
HCP	Enter into HCP parameter family and set the following parameters.	
SEr	1	Machine arranged for remote connection to PC.
6. Switch OFF and then switch ON the machine.		
GE_n	Enter into GEn parameter family.	
dIn	240	Initial Detergent Dosage.
rIn	18	Initial Rinse Aid Dosage.
dEt	16	Detergent dispensing during the wash cycle (loading during wash stage).
rA_i	7	Rinse aid dispensing during the rinse cycle (loading during boiler filling stage).
7. Switch OFF and then switch ON the machine.		

WARNING:

To set the board parameters , carefully follow the order given in this programming file, from point 1 to point 7.

WARNING:

When modifying parameter **dFL** , all the parameters (except those belonging to the **CFG** family) assume the default values according to the tables in section 11 DEFAULT VALUES. The parameters of the **CFG** family are not modified.

**EUCADD60****PROG 143**

1. Switch OFF and then switch ON the machine.

2. **CFG** Enter into CFG parameter family and set the following parameters:

LYP	0	Hood Type and undercounter.
bo1	0	Atmospheric boiler.
dao	2	Front loading function.
dFL	3	Default values for Undercounter models.
trc	1	SOFT START enabled.
b.t	1	Tank heater works only if boiler temperature reached.
btf	75	Enable filling tank by means of rinsing cycles.
LES	0	Detergent level switches not enabled.
U1	24	Select user interface hood type/ undercounter model.
rE	0	Regeneration cycle disabled.
Alr	0	Alarms not enabled.
AAE	0	Boiler electronic level sensor.
FrE	0	Resin regeneration cycle forcing.
SrU	10	Rinse water max. hardness.
bPo	50	Boiler heating control.

3. Switch OFF and then switch ON the machine.

4. Modify Factory parameters:

FAC Enter into FAC parameter family and set the following parameters.

bTt	84	Boiler Temperature Threshold.
bH1	96	Boiler temperature: alarm threshold.
BAJ	0	Boiler Temperature Adjust.
bP	0	Boiler standby function enabled.
bSt	2	Booster Function.
btd	3	During stand-by boiler is kept at lower temperature than Temperature Threshold.
tTt	63	Tub Temperature: Threshold.
tTH	2	Tub Temperature: HISTERESIS.
tH1	80	Tank temperature: alarm threshold.

5. Modify the cycle parameters:

LY1 Cycle 1 parameters family.

Ln1	0	Long Wash Phase [min].
Sh1	42	Short Wash Phase [s].
PA1	4	Pause [s].
r11	12	Rinse Phase Duration [s].
dr1	25	Drain [s].
FP1	2	Final Pause [s].

LY2 Cycle 2 parameters family.

Ln2	1	Long Wash Phase [min].
Sh2	42	Short Wash Phase [s].
PA2	4	Pause [s].
r12	12	Rinse Phase Duration [s].
dr2	25	Drain [s].
FP2	2	Final Pause [s].

**EUCADD60****PROG 143**

drn	Drain parameters family.		
idr	30	Initial Drain Phase Duration [s].	
Fdr	100	Final Drain Phase Duration [s].	
drt	0	Drain and cleaning mode.	
lbd	0	Wash tank water change frequency control disabled.	
dPA	Set other parameters.		
IPA	0	Initial Pause [s] (for ALL cycles).	
dLY	3	Delay for the 2 nd wash pump [s].	
Pdr	0	Drain Phase Duration at the end of washing phase [s].	
rPA	0	Duration of pause after the rinse cycle [s] (for ALL cycles).	
CF	0	Degrees Celsius display.	
rit	0	During the rinse stage, the display shows the boiler temperature.	
HCP	Enter into HCP parameter family and set the following parameters.		
SEr	1	Machine arranged for remote connection to PC.	
6. Switch OFF and then switch ON the machine.			
GEr	Enter into GEn parameter family.		
dIn	50	Initial Detergent Dosage.	
rIn	10	Initial Rinse Aid Dosage.	
dEt	6	Detergent dispensing during the wash cycle (loading during wash stage).	
rA,	4	Rinse aid dispensing during the rinse cycle (loading during boiler filling stage).	
7. Switch OFF and then switch ON the machine.			

WARNING:

To set the board parameters , carefully follow the order given in this programming file, from point 1 to point 7.

WARNING:

When modifying parameter *dFL* , all the parameters (except those belonging to the *lFG* family) assume the default values according to the tables in section 11 DEFAULT VALUES. The parameters of the *lFG* family are not modified.

**ZHT7 / ZHT76****PROG 144**

1. Switch OFF and then switch ON the machine.		
2.	CFG	Enter into CFG parameter family and set the following parameters:
	tYP	0 Hood Type and undercounter.
	boi	0 Atmospheric boiler.
	doo	1 Manual Hood.
	dFl	1 Default values for Hood Type models.
	trc	1 Enabled.
	b.t	0 Boiler heaters and tank heater work simultaneously.
	b.tF	75 Enable filling tank by means of rinsing cycles.
	LES	0 Detergent level switches not enabled.
	U1	9 Select user interface hood type/ undercounter model.
	rE	0 Regeneration cycle disabled (only for dishwashers with non-continuous water softener).
	Alr	1 Alarms enabled.
	RAE	0 Boiler electronic level sensor.
	FrG	0 Resin regeneration cycle forcing.
	SrU	10 Rinse water max. hardness.
	bPo	50 Boiler heating control.
3. Switch OFF and then switch ON the machine.		
4. Modify Factory parameters:		
	FAC	Enter into FAC parameter family and set the following parameters.
	b.tC	70 Boiler Temperature Threshold.
	b.Hi	0 Disable boiler high Temperature alarm (C 2).
	b.AJ	4 Boiler Temperature Adjust.
	b.P	1 Boiler standby function enabled.
	b.St	2 Booster Function.
	b.td	0 During stand-by boiler is kept at lower temperature than Temperature Threshold.
	t.tC	63 Tank Temperature: Threshold.
	t.Hi	0 Disable tank high Temperature alarm (C 3).
5. Modify the cycle parameters:		
	CY1	Cycle 1 parameters family.
	Ln1	0 Long Wash Phase [min].
	Sh1	36 Short Wash Phase [s].
	PA1	4 Pause [s].
	r.i1	12 Rinse Phase Duration [s].
	dr1	25 Drain [s].
	FP1	2 Final Pause [s].
	tL1	0 Long Wash Phase inTermal Label mode [min].
	tS1	59 Short Wash Phase inTermal Label mode [s].
	CY2	Cycle 2 parameters family.
	Ln2	1 Long Wash Phase [min].
	Sh2	12 Short Wash Phase [s].
	PA2	4 Pause [s].
	r.i2	12 Rinse Phase Duration [s].
	dr2	25 Drain [s].
	FP2	2 Final Pause [s].
	tL2	1 Long Wash Phase inTermal Label mode [min].
	tS2	12 Short Wash Phase inTermal Label mode [s].

**ZHT7 / ZHT76****PROG 144**

LY3	Cycle 3 parameters family.	
LW3	2	Long Wash Phase [min].
SW3	12	Short Wash Phase [s].
PA3	4	Pause [s].
RI3	12	Rinse Phase Duration [s].
DR3	25	Drain [s].
FP3	2	Final Pause [s].
TL3	2	Long Wash Phase in Termal Label mode [min].
TS3	12	Short Wash Phase in Termal Label mode [s].
BT3	0	Boiler Temperature Threshold for Cycle 3.
DRn	Drain parameters family.	
IDr	40	Initial Drain Phase Duration [s].
FDr	80	Final Drain Phase Duration [s].
DRt	0	Drain and cleaning mode.
CBd	0	Wash tank water change frequency control disabled.
dPA	Set other parameters.	
IPA	0	Initial Pause [s] (for ALL cycles).
dLY	3	Delay for the 2 nd wash pump [s].
PDr	0	Drain Phase Duration at the end of washing phase [s].
rPA	0	Duration of pause after the rinse cycle [s] (for ALL cycles).
CF	0	Degrees Celsius display.
RIt	0	During the rinse stage, the display shows the boiler temperature.
TLt	0	Termal Label mode disabled.
BTt	86	Boiler Temperature in Termal Label mode.
TTt	75	Tank Temperature in Termal Label mode.
THt	2	Tank Temperature histeresis in Termal Label mode.
HCP	Enter into HCP parameter family and set the following parameters.	
SEr	1	Machine arranged for remote connection to PC.
6. Switch OFF and then switch ON the machine.		
GEN	Enter into GEN parameter family.	
dIn	90	Initial Detergent Dosage.
rIn	10	Initial Rinse Aid Dosage.
dEt	6	Detergent dispensing during the wash cycle (loading during wash stage).
rA_i	4	Rinse aid dispensing during the rinse cycle (loading during boiler filling stage).
7. Switch OFF and then switch ON the machine.		

WARNING:

To set the board parameters , carefully follow the order given in this programming file, from point 1 to point 7.

WARNING:

When modifying parameter **dFL** , all the parameters (except those belonging to the **CFG** family) assume the default values according to the tables in section 11 DEFAULT VALUES. The parameters of the **CFG** family are not modified.

**ZUCIDC / EUCIDDC****PROG 145**

1. Switch OFF and then switch ON the machine.

2. **CFG** Enter into CFG parameter family and set the following parameters:

tyP	0	Hood Type and undercounter.
bo1	1	Pressure boiler.
dao	2	Front loading function.
dFl	3	Default values for Undercounter models.
trc	1	SOFT START enabled.
b.t	1	Tank heater works only if boiler temperature reached.
b.tF	0	The tank is filled into the traditional way.
LES	0	Detergent level switches not enabled.
U1	0	ACTIVE function disabled.
rE	0	Regeneration cycle disabled (only for dishwashers with non-continuous water softener).
Alr	1	Alarms enabled.
AAE	0	Boiler electronic level sensor.
FrE	0	Resin regeneration cycle forcing.
SrU	10	Rinse water max. hardness.
bPo	50	Boiler heating control.

3. Switch OFF and then switch ON the machine.

4. Modify Factory parameters:

FAC Enter into FAC parameter family and set the following parameters.

b.tE	86	Boiler Temperature Threshold.
bH1	96	Boiler temperature: alarm threshold.
BAJ	0	Boiler Temperature Adjust.
bP	1	Boiler standby function enabled.
bSt	2	Booster Function.
b.td	3	During stand-by boiler is kept at lower temperature than Temperature Threshold.
t.tE	63	Tub Temperature: Threshold.
t.H1	75	Tank temperature: alarm threshold.

5. Modify the cycle parameters:

CY1 Cycle 1 parameters family.

Ln1	1	Long Wash Phase [min].
Sh1	10	Short Wash Phase [s].
PA1	4	Pause [s].
r11	16	Rinse Phase Duration [s].
cr1	16	Cold Rinse Phase Duration [s].
dr1	30	Drain [s].
FP1	0	Final Pause [s].

CY2 Cycle 2 parameters family.

Ln2	1	Long Wash Phase [min].
Sh2	40	Short Wash Phase [s].
PA2	4	Pause [s].
r12	16	Rinse Phase Duration [s].
cr2	16	Cold Rinse Phase Duration [s].
dr2	30	Drain [s].
FP2	0	Final Pause [s].



LY3	Cycle 3 parameters family.	
LW3	3	Long Wash Phase [min].
SW3	40	Short Wash Phase [s].
PA3	4	Pause [s].
r3	16	Rinse Phase Duration [s].
cr3	16	Cold Rinse Phase Duration [s].
dr3	30	Drain [s].
FP3	0	Final Pause [s].
bt3	0	Boiler Temperature Threshold for Cycle 3.
drn	Drain parameters family.	
ldr	30	Initial Drain Phase Duration [s].
Fdr	80	Final Drain Phase Duration [s].
drk	0	Drain and cleaning mode.
cbd	0	Wash tank water change frequency control disabled.
dPA	Set other parameters.	
IPA	0	Initial Pause [s] (for ALL cycles).
dLY	3	Delay for the 2 nd wash pump [s].
Pdr	0	Drain Phase Duration at the end of washing phase [s].
rPA	0	Duration of pause after the rinse cycle [s] (for ALL cycles).
CF	0	Degrees Celsius display.
rit	0	During the rinse stage, the display shows the boiler temperature.
HCP	Enter into HCP parameter family and set the following parameters.	
SEr	1	Machine arranged for remote connection to PC.
6. Switch OFF and then switch ON the machine.		
GEN	Enter into GEN parameter family.	
dIn	50	Initial Detergent Dosage.
rIn	10	Initial Rinse Aid Dosage.
dEt	8	Detergent dispensing during the wash cycle (loading during wash stage).
rA1	4	Rinse aid dispensing during the rinse cycle (loading during boiler filling stage).
7. Switch OFF and then switch ON the machine.		

WARNING:

To set the board parameters , carefully follow the order given in this programming file, from point 1 to point 7.

WARNING:

When modifying parameter **dFL**, all the parameters (except those belonging to the **CFG** family) assume the default values according to the tables in section 11 DEFAULT VALUES. The parameters of the **CFG** family are not modified.

**NUC1DDRUKP****PROG 146**

1. Switch OFF and then switch ON the machine.

2. **CFG** Enter into CFG parameter family and set the following parameters:

tYP	0	Hood Type and undercounter.
boi	1	Pressure boiler.
dao	2	Front loading function.
dFL	3	Default values for Undercounter models.
trc	0	Disabled (for this appliance SOFT START is NOT possible).
b.t	2	During operation the priorities are booster heating element and wash pump, then tank heating element. Setting to 0 or 1 is prohibited.
btF	0	The tank is filled into the traditional way.
LES	0	Detergent level switches not enabled.
UI	24	Select user interface for LS5.
rE	0	Regeneration cycle disabled.
Alr	0	Alarms not enabled.
RAQ	0	Boiler electronic level sensor.
FrG	0	Resin regeneration cycle forcing.
SrU	10	Rinse water max. hardness.
bPo	50	Boiler heating control.

3. Switch OFF and then switch ON the machine.

4. Modify Factory parameters:

FAC Enter into FAC parameter family and set the following parameters.

btC	82	Boiler Temperature Threshold.
bH1	96	Boiler temperature: alarm threshold.
BAJ	3	Boiler Temperature Adjust.
bP	1	Boiler standby function enabled.
bSt	2	Booster Function.
btD	3	During stand-by boiler is kept at lower temperature than Temperature Threshold.
tC	63	Tub Temperature: Threshold.
tH1	75	Tank temperature: alarm threshold.

5. Modify the cycle parameters:

CY1 Cycle 1 parameters family.

Ln1	1	Long Wash Phase [min].
Sh1	40	Short Wash Phase [s].
PA1	4	Pause [s].
r1	16	Rinse Phase Duration [s].
dr1	30	Drain [s].
FP1	0	Final Pause [s].

CY2 Cycle 2 parameters family.

Ln2	2	Long Wash Phase [min].
Sh2	40	Short Wash Phase [s].
PA2	4	Pause [s].
r2	16	Rinse Phase Duration [s].
dr2	30	Drain [s].
FP2	0	Final Pause [s].

CY3 Cycle 3 parameters family.

Ln3	2	Long Wash Phase [min].
Sh3	40	Short Wash Phase [s].
PA3	4	Pause [s].
r3	16	Rinse Phase Duration [s].
dr3	30	Drain [s].
FP3	0	Final Pause [s].
bt3	0	Boiler Temperature Threshold for Cycle 3.

**NUC1DDRUKP****PROG 146**

drn	Drain parameters family.		
idr	30	Initial Drain Phase Duration [s].	
fdr	100	Final Drain Phase Duration [s].	
drt	0	Drain and cleaning mode.	
cbd	0	Wash tank water change frequency control disabled.	
dPA	Set other parameters.		
ipa	0	Initial Pause [s] (for ALL cycles).	
dly	3	Delay for the 2 nd wash pump [s].	
pdr	0	Drain Phase Duration at the end of washing phase [s].	
rPA	0	Duration of pause after the rinse cycle [s] (for ALL cycles).	
CF	0	Degrees Celsius display.	
rit	0	During the rinse stage, the display shows the boiler temperature.	
HCP	Enter into HCP parameter family and set the following parameters.		
SEr	1	Machine arranged for remote connection to PC.	
6. Switch OFF and then switch ON the machine.			
GEN	Enter into GEN parameter family.		
dln	165	Initial Detergent Dosage.	
rln	0	Initial Rinse Aid Dosage.	
dEt	182	Detergent dispenser works when LOAD SOLENOID VALVE in activated.	
rA1	61	Rinse Aid dispenser works when LOAD SOLENOID VALVE in activated.	
7. Switch OFF and then switch ON the machine.			

WARNING:

To set the board parameters , carefully follow the order given in this programming file, from point 1 to point 7.

WARNING:

When modifying parameter **dFL** , all the parameters (except those belonging to the **CFG** family) assume the default values according to the tables in section 11 DEFAULT VALUES. The parameters of the **CFG** family are not modified.

WARNING:

Per limitare l'assorbimento massimo a 13A (l'apparecchiatura è monofase con spina 13A UK), non devono funzionare contemporaneamente:

- la resistenza della vasca e la pompa di lavaggio,
- la resistenza boiler e la resistenza della vasca.



11 DEFAULT VALUES

Default 1 - HOOD TYPE

ON/OFF + CYCLE1 keys		ON/OFF + CYCLE2 keys										
Gen →	Ent	FAC →	CY1 →	CY2 →	CY3 →	drn →	dPA →	ran →	HCP →	CFG	dbG	
dIn: 90	CYC	bEt: 78	Ln1: 0	Ln2: 0	Ln3: 1	ldr: 40	lPA: 0	rEL	SEr: 1	tYP: 0	t 1: 15	
rIn: 10	cYc	bEtH: 2	Sh1: 35	Sh2: 45	Sh3: 40	Fdr: 80	dLY: 3	rLS	Adr: 1	baic: 0	t 2: 200	
dEt: 8	rSt	bM: 96	PA1: 4	PA2: 4	PA3: 4	drb: 0	Pdr: 0	ACC	Prn: 1	daoc: 1	t 3: 15	
rA: 4	nCY	bLo: 1	Pr1: 0	Pr2: 0	Pr3: 0	cbd: 0	rPA: 0	CA11	bt: 90	dFL: -	t 4: 10	
	drn	bFL: 5	r1: 16	r2: 16	r3: 16	dta: 18	CF: 0	C 8	bM: 10	trc: 0	t 5: 20	
	rCY	bAd: 4	cr1: 0	cr2: 0	cr3: 0		rk: 0	F21	tt: 68	bt: 1	t 6: 20	
	nrE	bP: 1	dr1: 16	dr2: 16	dr3: 16		PPL: 0		tM: 10	btF: 75	AL: 0	
	rES	bSt: 2	FP1: 0	FP2: 0	FP3: 0		dE: 5			LES: 0	tk: 100	
		btd: 0	tL1: 0	tL2: 1	tL3: 2		tLE: 0			U1: 9		
		tEt: 63	tS1: 59	tS2: 12	tS3: 12		btL: 86			rE: 0		
		tEtH: 5			bt3: 0		tEtL: 75			ALr: 1		
		tM: 75					tMt: 2			ARG: 0		
		tLo: 1								FrG: 0		
		tFL: 20								SrU: 10		
										bPo: 50		



Default 2 - POT WASHER

ON/OFF +
CYCLE1
keys

GE n →	C nt
dIn: 240	CYC
rIn: 18	cyc
dEt: 16	rSt
rR: 7	nCY
	drn
	rCY
	nrE
	rES

ON/OFF +
CYCLE2
keys

F AC →	C Y1 →	C Y2 →	C Y3 →	d rn →	d PA →	r an →	H CP →	C FG	d bG
bEt: 78	Ln1: 2	Ln2: 5	Ln3: 8	ldr: 40	lPA: 2	rEL	SEr: 1	tYP: 1	t 1: 15
bEtH: 2	Sh1: 34	Sh2: 34	Sh3: 34	Fdr: 80	dLY: 3	rLS	Adr: 1	bo: 0	t 2: 200
bM: 96	PA1: 4	PA2: 4	PA3: 4	drE: 0	Pdr: 0	ACC	Prn: 1	dao: 2	t 3: 15
bLo: 1	Pr1: 0	Pr2: 0	Pr3: 0	cbd: 0	rPA: 0	CA1	bt: 90	dFL: -	t 4: 10
bFL: 5	r1: 20	r2: 20	r3: 20	dtoc: 48	CF: 0	C 8	bM: 10	trc: 0	t 5: 20
bAd: 4	cr1: 0	cr2: 0	cr3: 0		rit: 0	F21	tt: 68	b_t: 1	t 6: 20
bP: 1	dr1: 20	dr2: 20	dr3: 20		PPL: 0		tM: 10	btF: 75	RL: 0
bSt: 4	FP1: 0	FP2: 0	FP3: 0		EdE: 5			LES: 0	lth: 100
bEd: 0	tL1: 0	tL2: 1	tL3: 2		tLE: 0			U1: 9	
EtE: 63	tS1: 59	tS2: 12	tS3: 12		btL: 86			rE: 0	
EtH: 5			bt3: 0		EtL: 75			RLr: 1	
EtM: 75					tMt: 2			RRG: 0	
EtLo: 1								FrG: 0	
EtFL: 40								SrU: 10	
								bPo: 50	



Default 3 - UNDERCOUNTER

ON/OFF +
CYCLE1
keys

GE n →	Ent
dIn: 50	cYc
rIn: 10	cYc
dEt: 8	rSt
rR: 4	nCY
	drn
	rCY
	nrE
	rES

ON/OFF +
CYCLE2
keys

FA C →	CY 1 →	CY 2 →	CY 3 →	dr n →	dPA →	ran →	HE P →	CF G	db G
bEt: 80	Ln1: 1	Ln2: 1	Ln3: 3	ldr: 30	lPA: 0	rEL	SEr: 1	tYP: 0	t 1: 15
bEtH: 2	Sh1: 10	Sh2: 40	Sh3: 40	Fdr: 80	dLY: 3	rLS	Adr: 1	bo: 0	t 2: 200
bM: 96	PA1: 4	PA2: 4	PA3: 4	drE: 0	Pdr: 0	ACC	Prn: 1	dao: 2	t 3: 15
bLo: 1	Pr1: 0	Pr2: 0	Pr3: 0	cbd: 0	rPA: 0	CA1	bE: 90	dFL: -	t 4: 10
bFL: 5	r1: 16	r2: 16	r3: 16	dtoc: 18	CF: 0	E 8	bM: 10	trc: 1	t 5: 20
bAd: 0	cr1: 0	cr2: 0	cr3: 0		rE: 0	F21	bE: 68	bE: 1	t 6: 20
bP: 1	dr1: 30	dr2: 30	dr3: 30		PPL: 0		tM: 10	bEtF: 75	AL: 0
bSt: 2	FP1: 0	FP2: 0	FP3: 0		EdE: 5			LES: 0	tk: 100
bEd: 3	tL1: 0	tL2: 1	tL3: 2		tLE: 0			U1: 9	
tEt: 63	tS1: 59	tS2: 12	tS3: 12		bEtL: 86			rE: 0	
tEtH: 5			bEt3: 0		tEtL: 75			ALr: 1	
tM: 75					tMt: 2			ARG: 0	
tLo: 1								FrG: 0	
tFL: 20								SrU: 10	
								bPo: 50	



12 USER INTERFACE AND MAIN BOARD CONNECTORS

12.1 MAIN MALFUNCTIONS NOT DUE TO THE MAIN BOARD

The display shows CL05E with door/hood closed	Check door/hood micro/sensor
No cycle starts	Check the user interface buttons (have they remained pressed? etc.)
A cycle fails to start	Is a user interface button extension missing?
After replacing the main board only the 3 rd cycle starts	The main board is still configured for LS5/WT4.
Cycle time longer than that foreseen	Does the boiler work? Is the feed water at 50°C?
Noisy wash pump (only on HT and PP versions)	Check the current for single phase during operation.

12.2 CONNECTORS LAYOUT

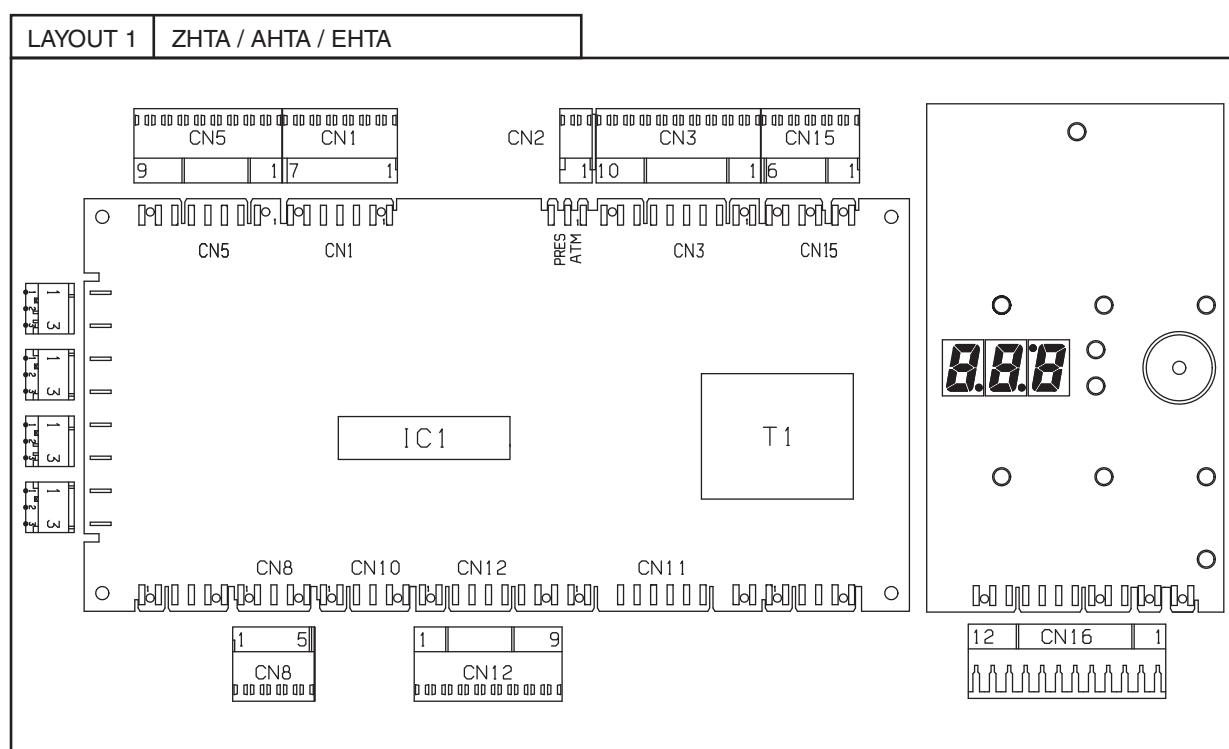

KEY

- CN1** Rinse pump/wash pump/solenoid valve outputs
- CN2** Pressure/atmospheric dishwasher solenoid valve connection
- CN3** Detergent/rinse aid dispenser and drain pump outputs
- CN5** Tank/boiler temperature sensor inputs
- CN8** Energy peak controller input
- CN12** User interface inputs/outputs
- CN15** Overflow/tank level/board feed input
- CN16** User interface inputs/outputs and hood/door sensor input

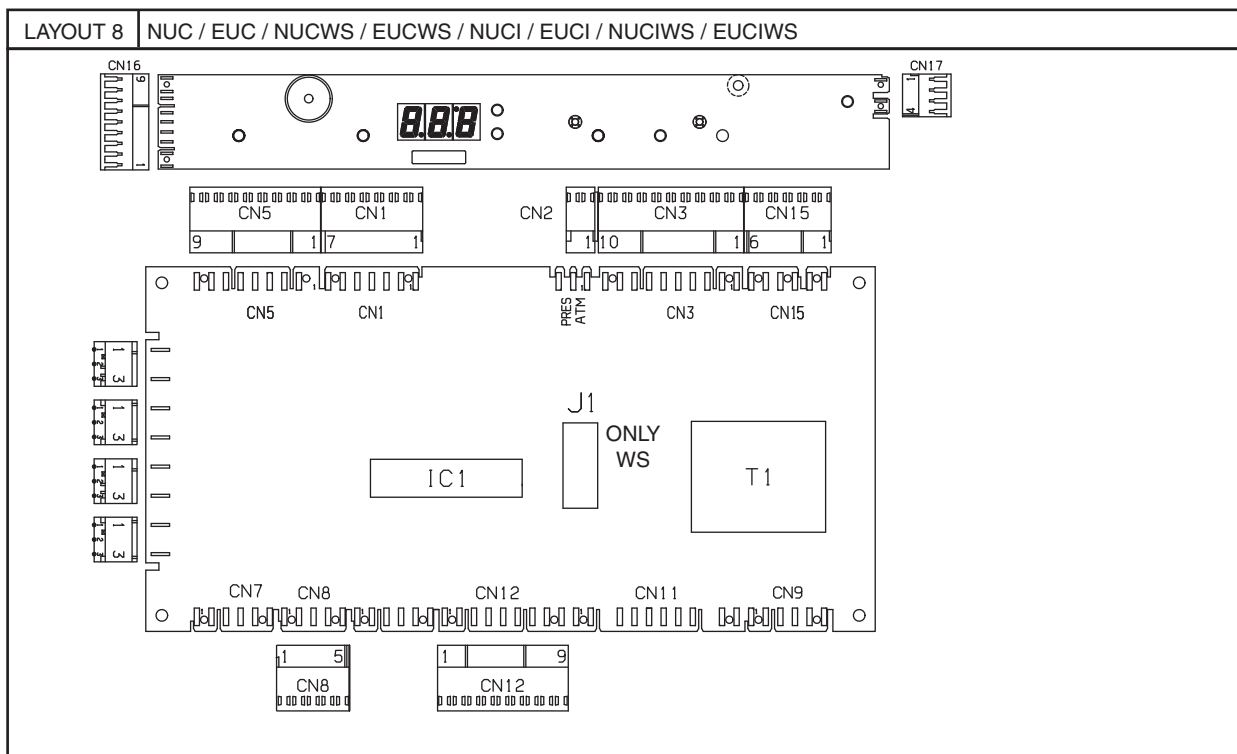
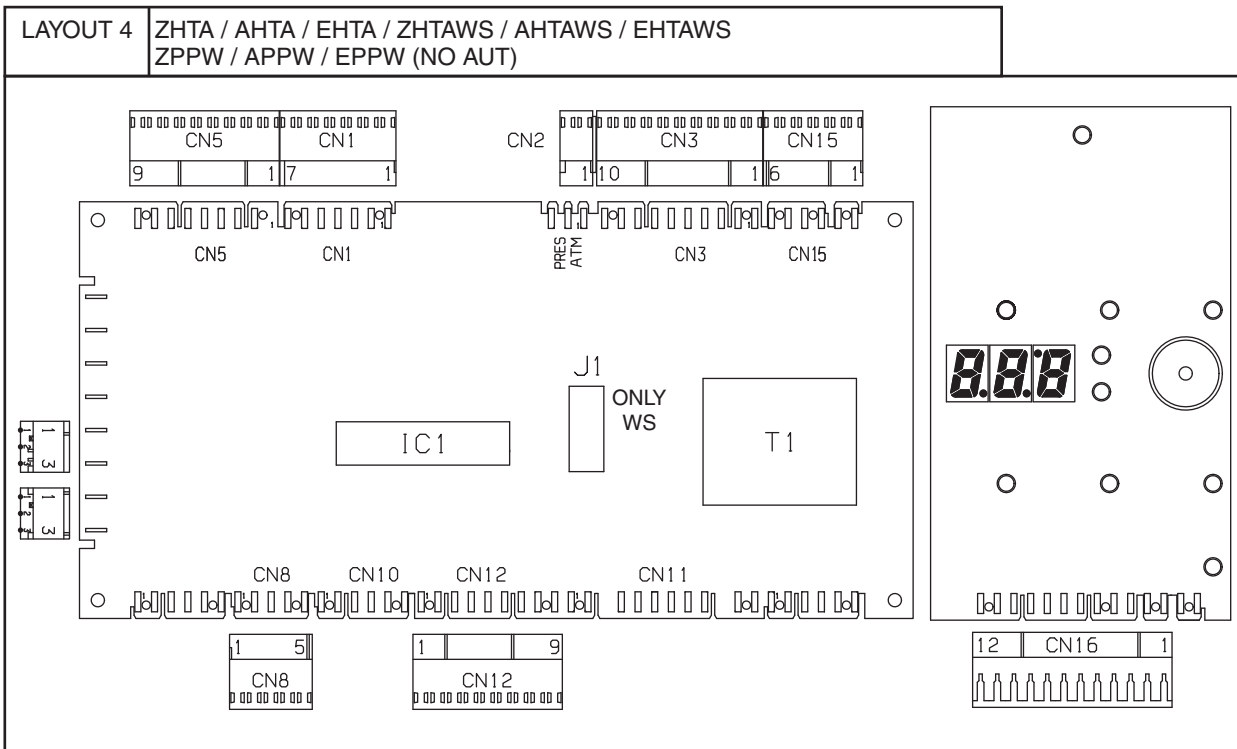

KEY

- CN1** Rinse pump/wash pump/solenoid valve outputs
- CN2** Pressure/atmospheric dishwasher solenoid valve connection
- CN3** ECOTEMP transformer, detergent/rinse aid dispenser and drain pump outputs
- CN5** Tank/boiler temperature sensor inputs
- CN7** Hand safety system microswitch input
- CN8** Energy peak controller input
- CN10** Safety and upper/lower limit switch input
- CN11** Hand safety system input - Gear motor current control input - Gear motor polarity inversion connection
- CN12** User interface inputs/outputs
- CN15** Overflow/tank level/board feed input
- CN16** User interface inputs/outputs and hood/door sensor input

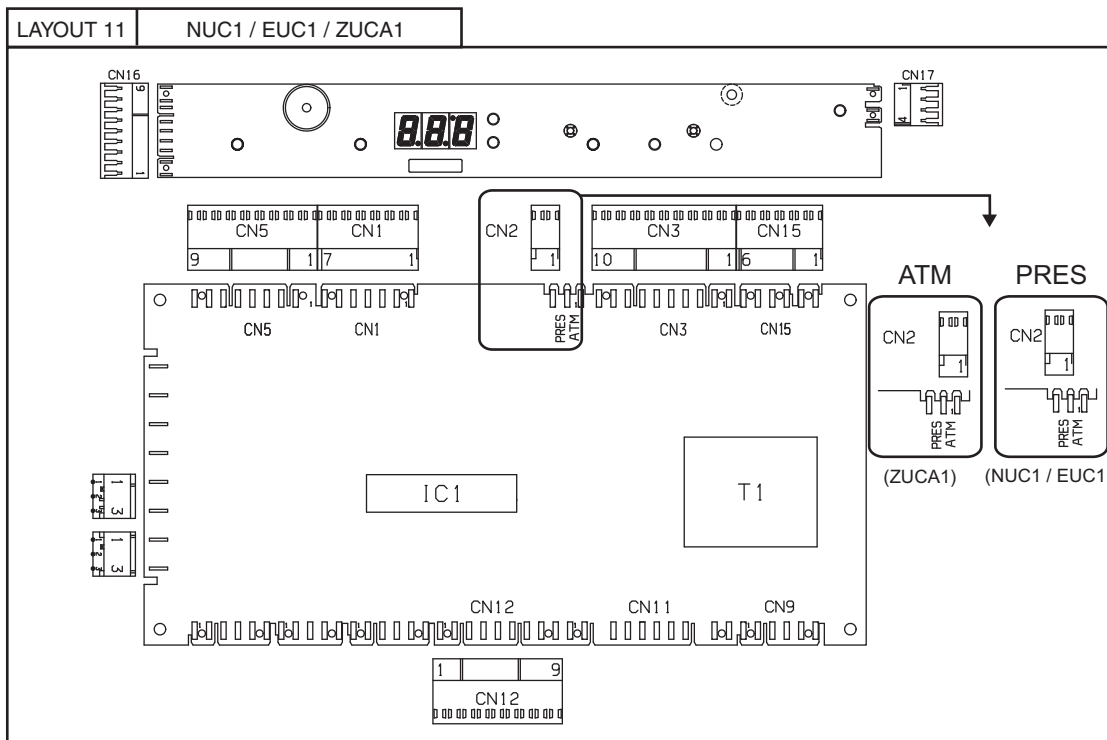
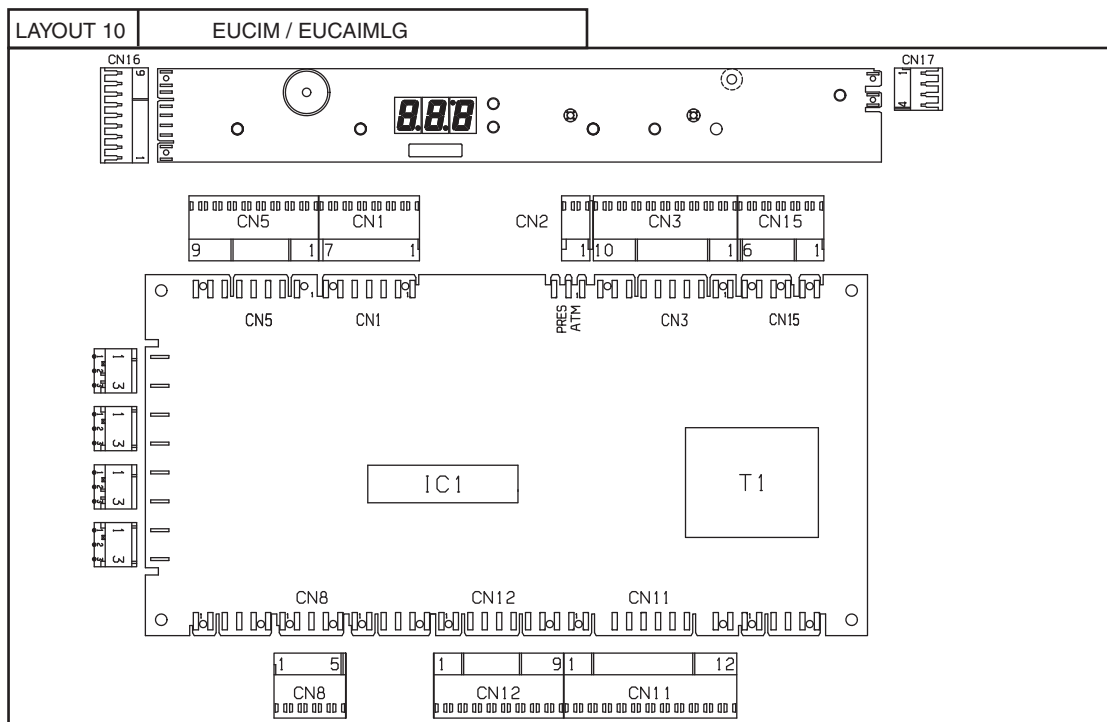

KEY

- CN1** Rinse pump/wash pump/solenoid valve outputs
- CN2** Pressure/atmospheric dishwasher solenoid valve connection
- CN3** Detergent/rinse aid dispenser and drain pump outputs
- CN5** Tank/boiler temperature sensor inputs
- CN8** Energy peak controller input
- CN11** Door lock electromagnet output
- CN12** User interface inputs/outputs
- CN15** Overflow/tank level/board feed input
- CN16** User interface inputs/outputs and hood/door sensor input
- CN17** Door microswitch connector

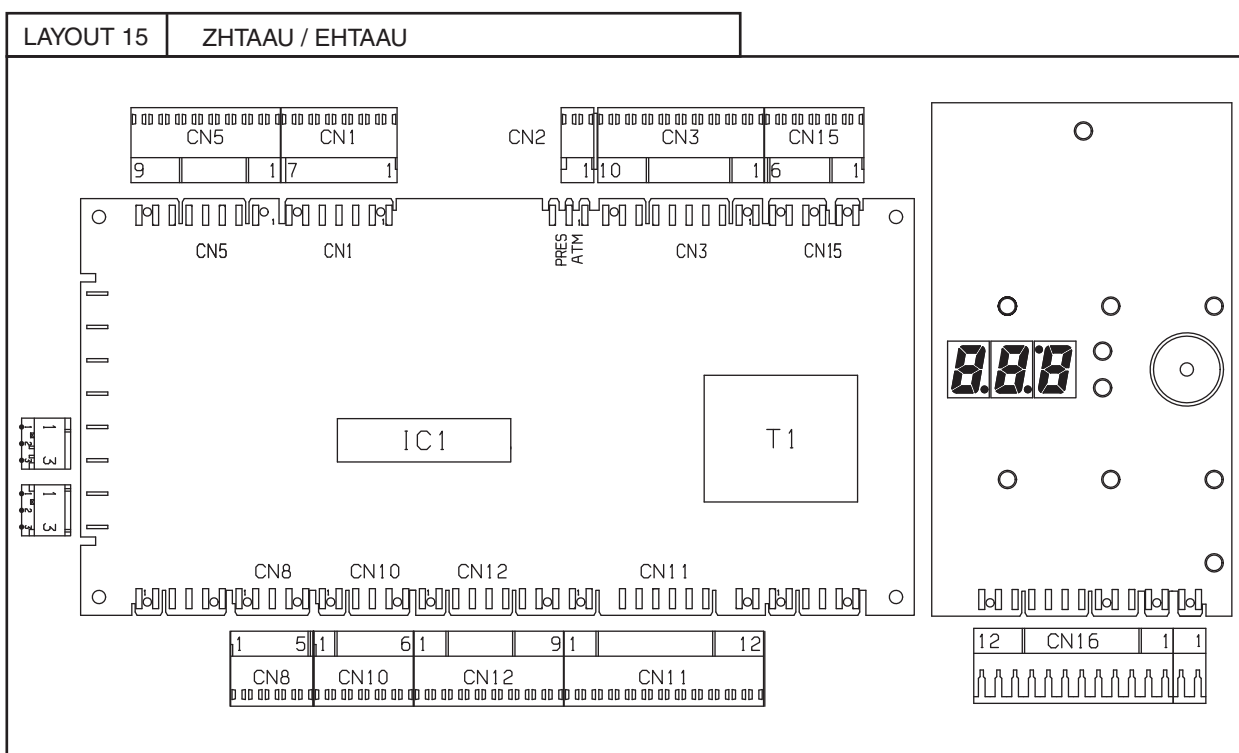
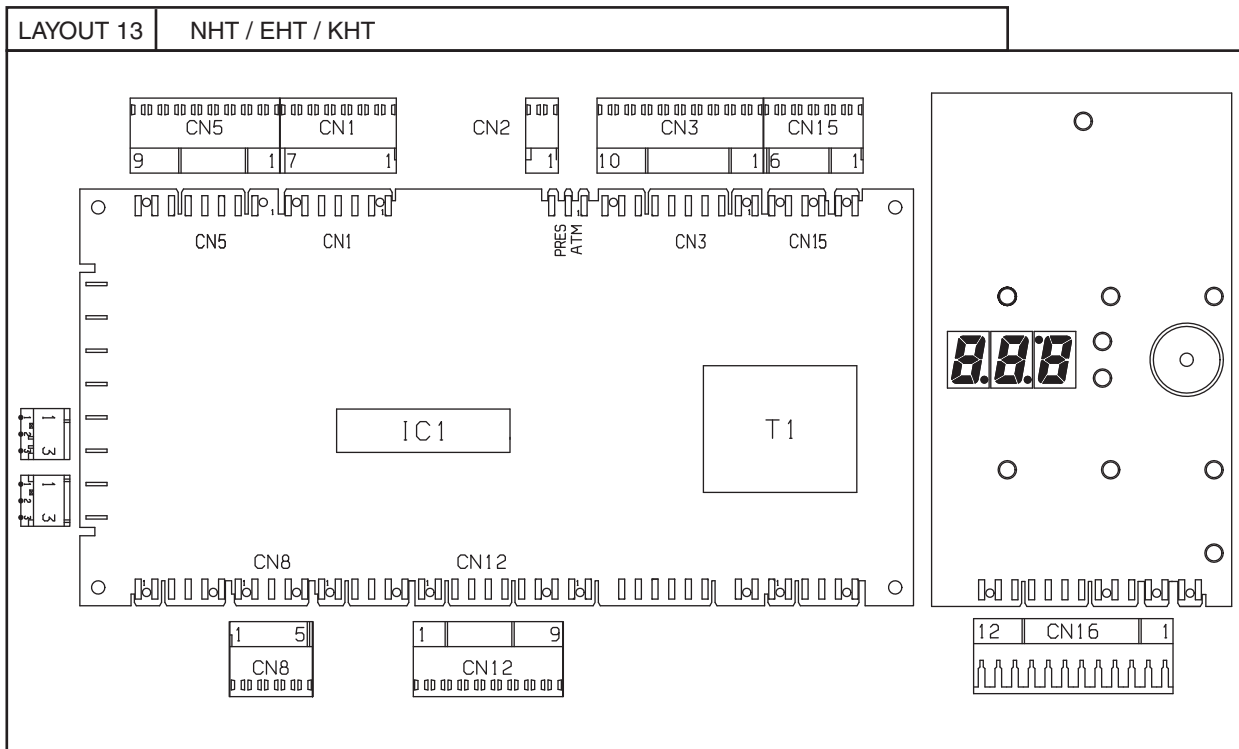

KEY

- CN1** Rinse pump/wash pump/solenoid valve outputs
- CN2** Pressure/atmospheric dishwasher solenoid valve connection
- CN3** ECOTEMP transformer, detergent/rinse aid dispenser and drain pump outputs
- CN5** Tank/boiler temperature sensor inputs
- CN8** Energy peak controller input
- CN11** Hood lock electromagnet output
- CN12** User interface inputs/outputs
- CN15** Overflow/tank level/board feed input
- CN16** User interface inputs/outputs and hood/door sensor input

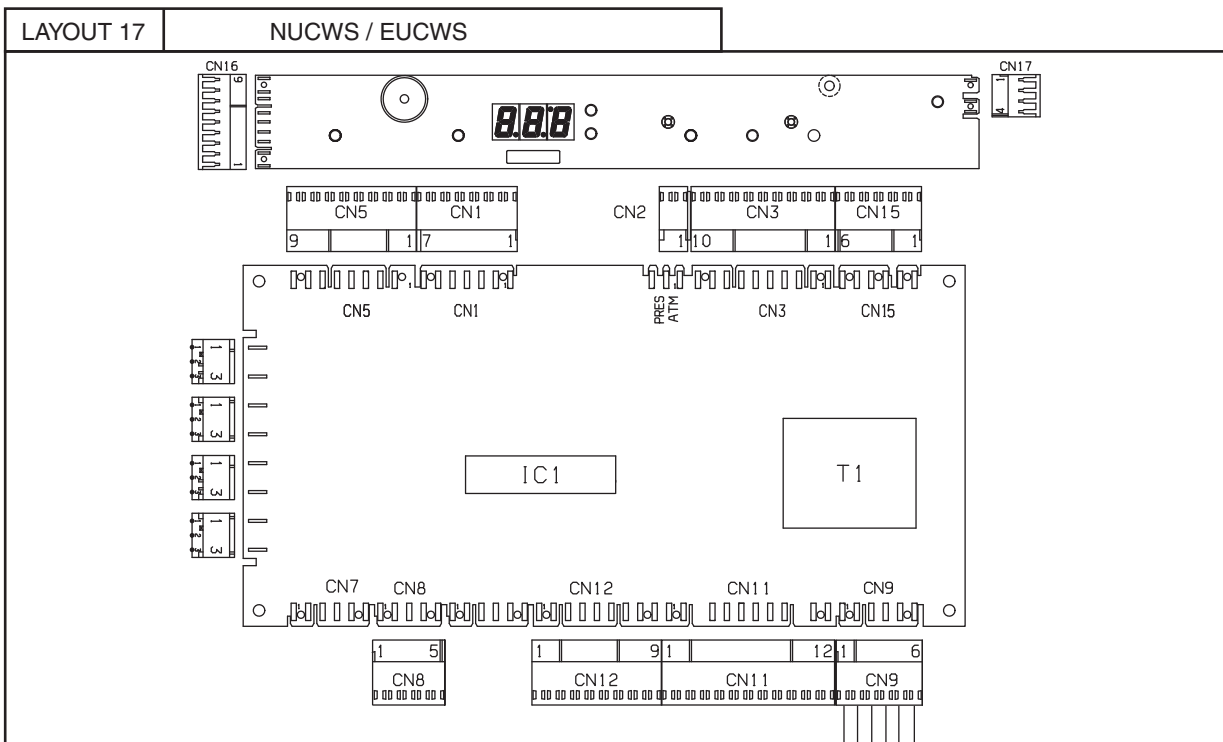
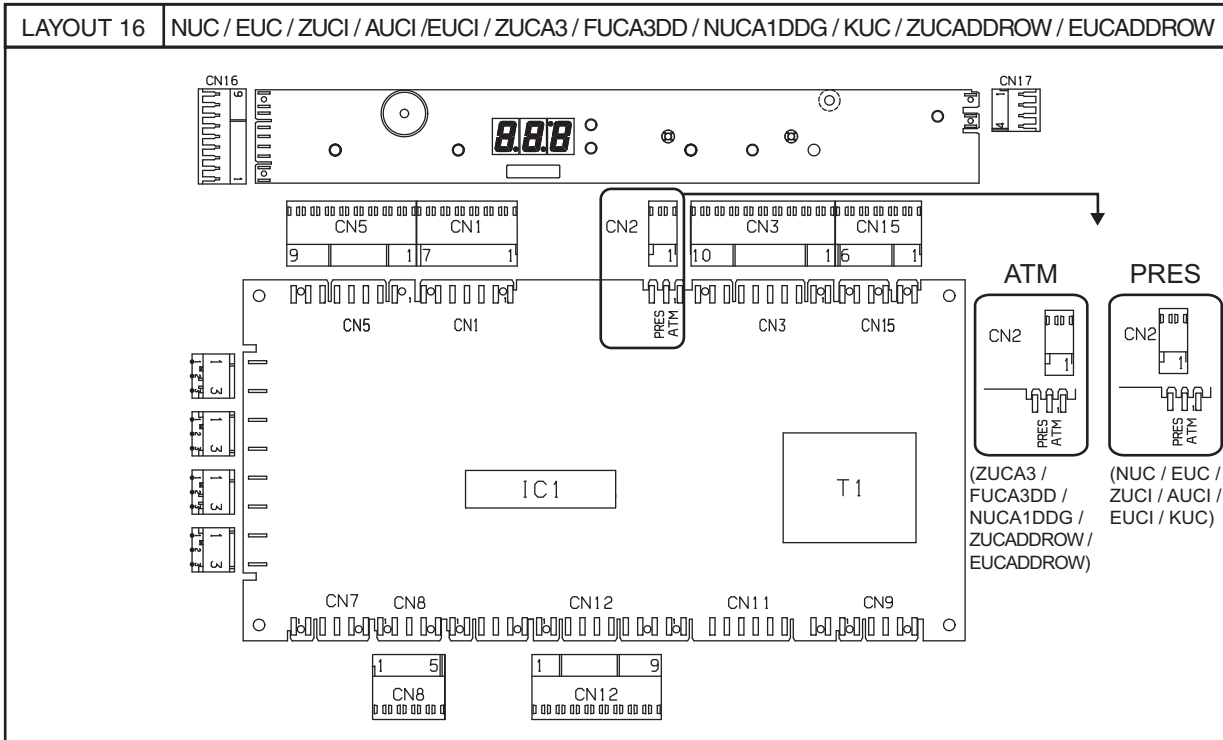

KEY

- CN1** Rinse pump/wash pump/solenoid valve outputs
- CN2** Pressure/atmospheric dishwasher solenoid valve connection
- CN3** Detergent/rinse aid dispenser and drain pump outputs
- CN5** Tank/boiler temperature sensor inputs
- CN8** Energy peak controller input
- CN9** Salt receptacle drain pump and low pressure solenoid valve outputs
- CN11** Brine solenoid valve output
- CN12** User interface inputs/outputs
- CN15** Overflow/tank level/board feed input
- CN16** User interface inputs/outputs and hood/door sensor input
- CN17** Door microswitch connection

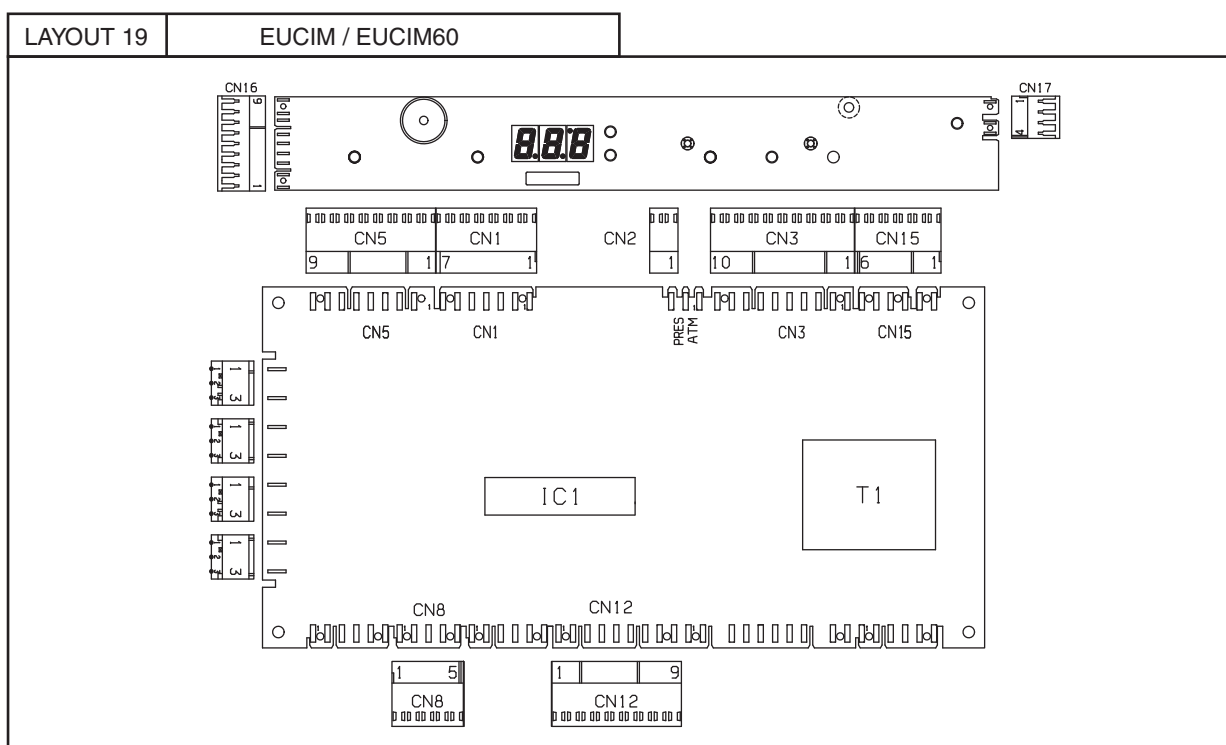
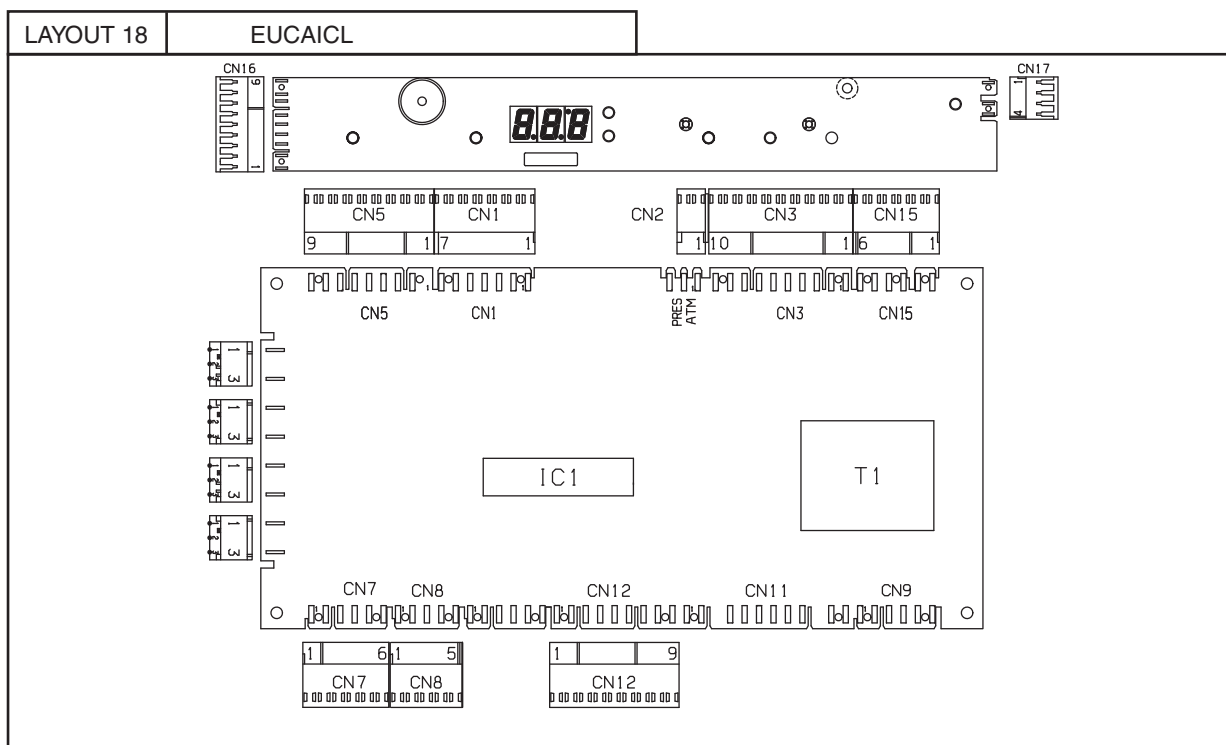

KEY

- CN1** Rinse pump/wash pump/solenoid valve outputs
- CN2** Pressure/atmospheric dishwasher solenoid valve connection
- CN3** Detergent/rinse aid dispenser and drain pump outputs
- CN5** Tank/boiler temperature sensor inputs
- CN7** Detergent/rinse aid level sensors input
- CN8** Energy peak controller input
- CN12** User interface inputs/outputs
- CN15** Overflow/tank level/board feed input
- CN16** User interface inputs/outputs and hood/door sensor input
- CN17** Door microswitch connection

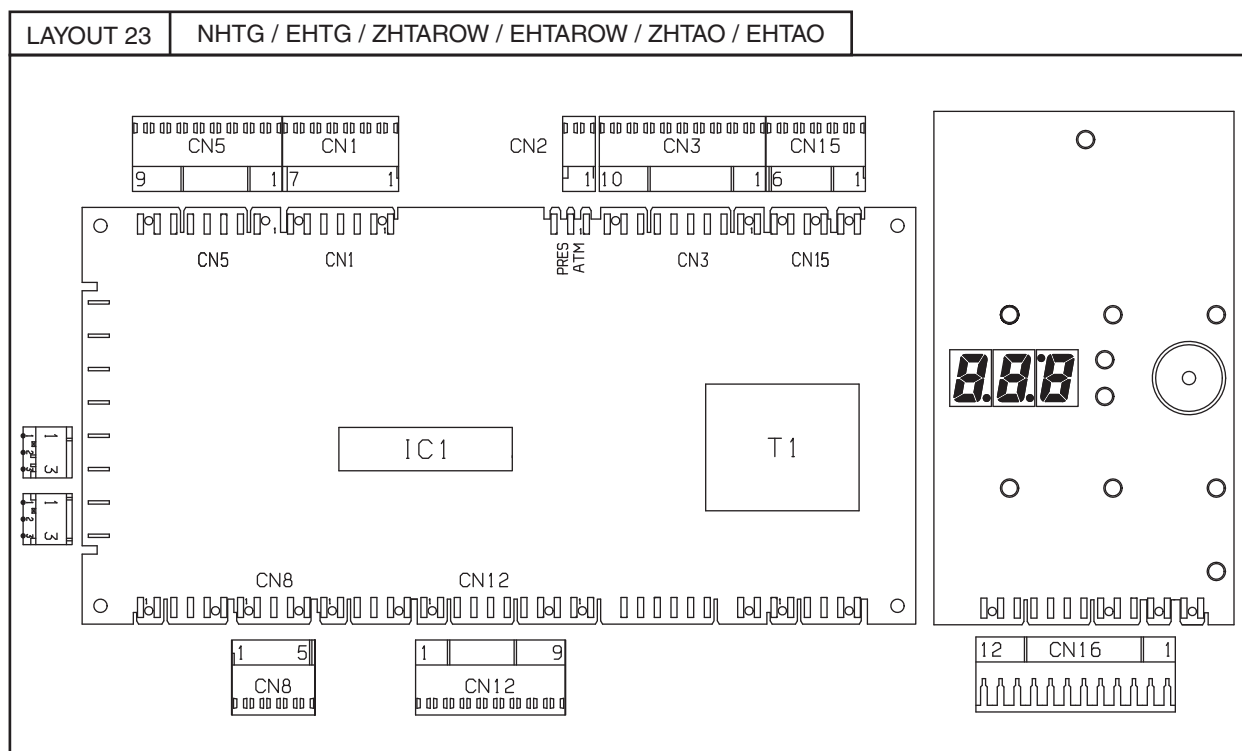
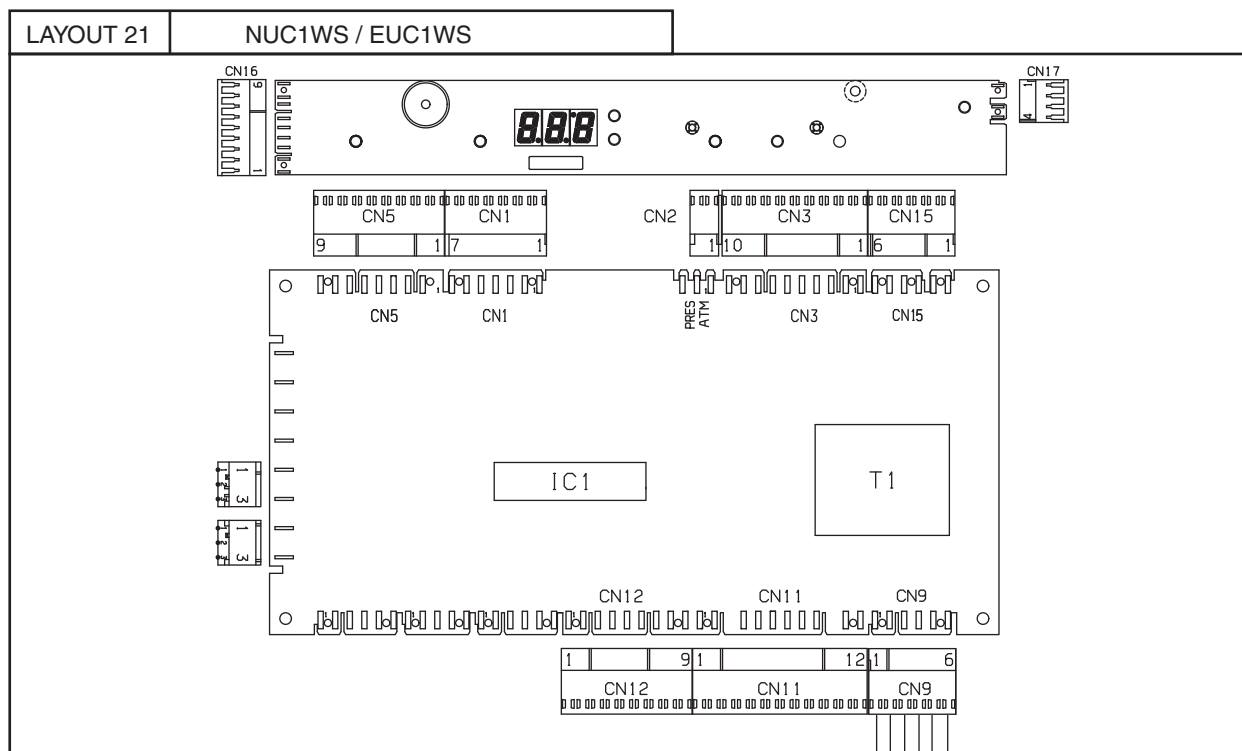

KEY

- CN1** Rinse pump/wash pump/solenoid valve outputs
- CN2** Pressure/atmospheric dishwasher solenoid valve connection
- CN3** Detergent/rinse aid dispenser and drain pump outputs
- CN5** Tank/boiler temperature sensor inputs
- CN8** Energy peak controller input
- CN9** Salt receptacle drain pump and low pressure solenoid valve outputs
- CN11** Brine solenoid valve output
- CN12** User interface inputs/outputs
- CN15** Overflow/tank level/board feed input
- CN16** User interface inputs/outputs and hood/door sensor input
- CN17** Door microswitch connection



13 ALARM MESSAGES AND TROUBLESHOOTING

13.1 ALARMS THAT STOP THE DISHWASHER

A 1	Want of water
	<p>Is the water cock open? Does the water load solenoid valve work? Is the water feed flow a min. of 5 l/min? Is the water inlet filter clean? Is the load solenoid valve filter clean? Is the overflow inserted? Is the main board (ATM-PRES) CN2 connector correctly positioned? Do the tank/boiler pressure switches work properly?</p>
E 8	Rinsing is not done regularly for 2 consecutive cycles
	<p>Are the rinse arms clogged? Does the rinse pump work correctly? Is there water in the level sensor tube? Is there scale in the boiler? Does the boiler level sensor work properly?</p>
	<p>ONLY FOR MACHINES WITH CONTINUOUS WATER SOFTENER: Does the boiler level sensor located inside the water softener work properly? Does the float of the boiler level sensor, located inside the water softener, work properly? Is it free to move upwards and downwards and vice versa? Is the connection from the boiler level sensor to the main board efficient?</p>
	<p>ATTENZIONE: RESETTING THIS ALARM WITHOUT FIRST ELIMINATING THE CAUSE IS DANGEROUS; THE BOILER HEATING ELEMENTS COULD WORK DRY, FURTHER DAMAGING THE INTERNAL PARTS OF THE DISHWASHER.</p> <p>ATTENZIONE: E 8 IT MUST BE MANUALLY RESET AFTER ELIMINATING THE CAUSE OF THE MALFUNCTION.</p>
E 9	Automatic hood out of order
	See par. 13.1.1 ALARM CODES FOR AUTOMATIC HOOD TYPE DISHWASHERS.

13.1.1 ALARM CODES FOR AUTOMATIC HOOD TYPE DISHWASHERS

When the alarm **E 9** appears, to facilitate fault-finding another parameter providing a more detailed indication has been introduced.

The parameter is **AL** and is found in the **dbC** family.

The possible cause of the anomaly can be found (see table below) ?according to the value of the parameter **AL**.

With pot washers the cause that generated a **b3** type alarm can also be found.

E.g.: With an automatic hood type the alarm **E 9** appears.

Access the parameter **AL** in the **dbC** family.

AL . 8 ⇒ the top limit switch could be disconnected or interrupted.

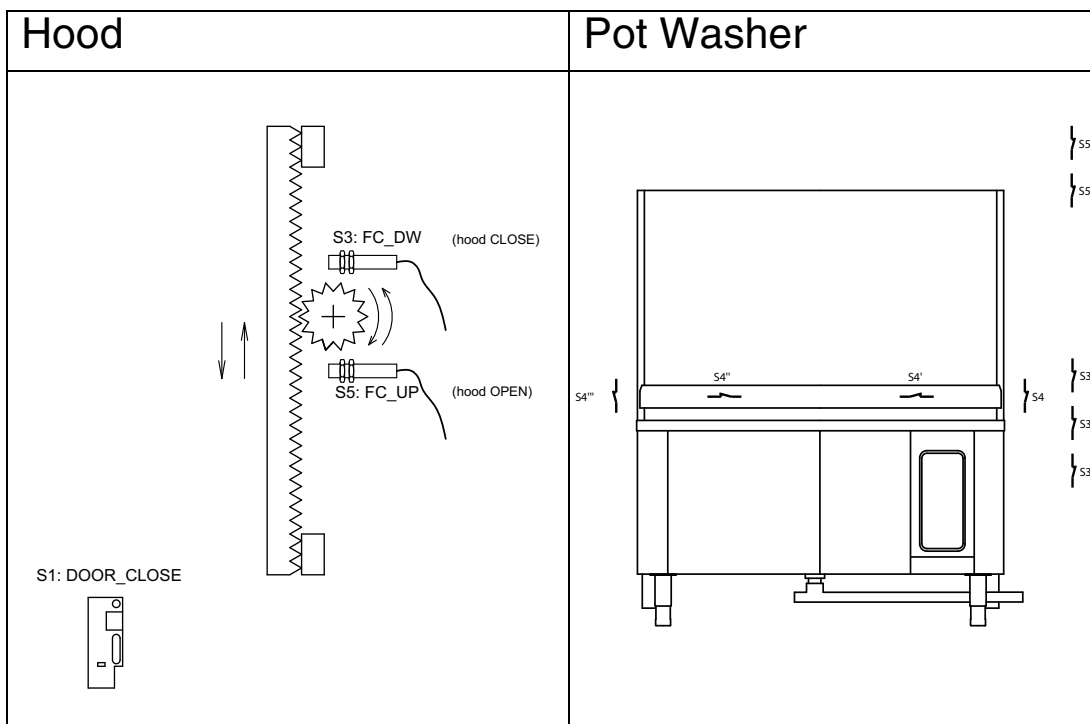

<p>AL_1</p>	<p>Appears with hood closed if the top limit switch (FC_UP) cuts in.</p>	<p>Appears with hood closed, if:</p> <ul style="list-style-type: none"> - the bottom limit switch (S3) returns to the rest position; - the top limit switch (S5) cuts in; - S3'' does not cut in.
<p>AL_2</p>	<p>During lifting, the bottom limit switch (FC_DW) has not returned to the rest position.</p> <p>The limit switch must return to the rest position within a time given by the parameter t_{S3}:</p> <p>a) check that the motor works.</p>	<p>b 3</p> <p>During the initial lifting phase the bottom limit switch (S3) must return to the rest position within a time given by the parameter t_{S3}? otherwise the alarm b 3 appears.</p> <ul style="list-style-type: none"> - S3 could be stuck. - S5' could be disconnected. <p>On installation this alarm can occur due to incorrect sequence of the phases: invert the two phases on the power supply terminal board</p>
<p>AL_3</p>		<p>Appears if during lifting S3'' does not return to the rest position within a time $t_{S3''}$.</p>
<p>AL_4</p>	<p>Appears if the bottom limit switch (FC_DW) cuts in during lifting.</p> <p>(Polarity/motor rotation direction inverted?!).</p>	<p>b 3</p> <p>Appears if the bottom limit switch (S3) cuts in during lifting.</p> <p>On installation this alarm can occur due to incorrect sequence of the phases: invert the two phases on the power supply terminal board.</p>



AL_5	TIMEOUT -The time taken for hood lifting was more than the time fixed by parameter t 2 : a) check that the motor works.	TIMEOUT - IThe time taken for lifting was more than the time fixed by parameter t 2 . Check correct operation of the: a) motor (thermal protection N7); b) top limit switch (S5 and S5').
AL_6	The hood is open but the bottom limit switch (FC_DW) has cut in.	Appears with hood fully open, if: - the limit switch (S5) returns to the rest position; - the bottom limit switch (S3) cuts in; - S3" cuts in.
AL_7	Appears if with hood fully open the "door closed" microswitch cuts in.	Appears if with hood fully open the "door closed" microswitch cuts in. - S5 could be disconnected.
AL_8	During lowering, the top limit switch (FC_UP) has not returned to the rest position. The limit switch must return to the rest position within a time given by parameter t 6 : a) check that the motor works; b) (Polarity/motor rotation direction inverted?!)..	b 3 During the initial lowering phase the top limit switch (S5) must return to the rest position within a time given by the parameter t 6 otherwise the alarm b 3 appears. - S5 could be stuck. - S3' could be disconnected. On installation, this alarm can occur due to incorrect sequence of the phases: invert the two phases on the power supply terminal board.
AL_9	-	Appears if the bottom limit switch S3 cuts in before S3" during lowering.
AL_10	Appears if the top limit switch (FC_UP) cuts in during lowering. (Polarity/motor rotation direction inverted?!).	b 3 Appears if the top limit switch (S5) cuts in during lowering. On installation, this alarm can occur due to incorrect sequence of the phases: invert the two phases on the power supply terminal board.
AL_11	TIMEOUT - The time taken for hood closing was more than the time fixed by parameter t 2 : a) check that the motor works.	TIMEOUT - The time taken for lowering was more than the time fixed by parameter t 2 . - S3' could be disconnected.
AL_12	-	Appears during hood lowering if, after S3" cuts in, the bottom limit switch S3 does not cut in within the time fixed by parameter t 3 .



AL_13	-	<p>The two hand safety contacts K and K' must be both closed or both open. If this does not occur the alarm appears.</p> <p>- One of the two relays (K or K') could be stuck or disconnected. (See parameter 4)</p>
AL_14	<p>Limit switch combination not allowed: top limit switch (FC_UP) and bottom limit switch (FC_DW) activated at the same time!</p>	<p>Limit switch combination not allowed. Appears if one of the following combinations occurs:</p> <ul style="list-style-type: none"> - top limit switch (S5) and bottom limit switch (S3) both activated (S3 and S5 could be disconnected); - top limit switch S5 and S3" both cut in; - bottom limit switch (S3) cut in but not S3".
AL_20	<p>During lifting, the current absorbed by the lifting motor has exceeded the threshold (see parameter 14h):</p> <p>a) excessive mechanical force during lifting..</p>	-
AL_21	<p>During lowering, the current absorbed by the lifting motor has exceeded the threshold (see parameter 14h):</p> <p>excessive mechanical force during lowering.</p>	-
AL_22 AL_23 AL_24 AL_25	<p>The hood should be stopped but the card detects a high current absorption by the lifting motor:</p> <p>the relay RL18/RL19 could be stuck; feeder connector CN32 could be disconnected.</p>	-



13.2 ALARMS THAT DON'T STOP THE DISHWASHER

(SHOWN ON THE USER INTERFACE AT REGULAR INTERVALS)

WARNING:

Alarms marked with the Θ symbol from Serial Number 821 have become alarms which do not lock the machine.

b 1	Drain not efficient
	<p>Has the overflow been removed? Is the water drain blocked? Is the drain pump blocked? Are the air trap and tank pressure switch clean? Is there a constriction in the drain tube? Is the pump breather pipe returning to the tank clogged or constricted? Does the tank pressure switch work properly? Is there a hole in the drain tube (only for versions with drain pump)?</p>
b 2	Overflow alarm
	<p>Is the water drain blocked? Are the air trap and tank pressure switch clean? Does the tank pressure switch work properly? Is the load solenoid valve blocked? (E1 - LOAD_EV) Is the load solenoid valve relay stuck? (RL8 - LOAD_EV)</p>
Θ [1	Boiler temperature rise too fast
	<p>Does the boiler level sensor work properly? The boiler could be empty. Are non-original power resistances installed?</p>
Θ [2	Boiler temperature too high
	<p>Has the boiler temperature been changed (b 1 - increased above 90°C)? Has the software alarm value been modified (b 4)? Does the boiler level sensor work properly? Is the boiler relay stuck (see RL2, RL3, RL4)?</p>
Θ [3	Tank temperature too high
	<p>Is the feed water above 60°C? Has the software alarm value been modified (b 4)? Is the rinse water temperature too high? Is the tank relay stuck (RL5 - TUB_HEAT)?</p>
Θ [4	Tank temperature sensor out of order
	<p>Is the temperature sensor broken or disconnected (NT1)? Is the temperature sensor connector correctly inserted?</p>
Θ [5	Tank temperature sensor out of order
	<p>Is the temperature sensor short-circuited (NT1)?</p>



ⓘ E 6	Boiler temperature sensor out of order
	Is the temperature sensor broken or disconnected (NT2)? Is the temperature sensor connector correctly inserted?
ⓘ E 7	Boiler temperature sensor out of order
	Is the temperature sensor short-circuited (NT2)?
ⓘ E 10	Rinse temperature sensor out of order (only on machines with temperature sensor on the rinse circuit)
	Is the temperature sensor broken or disconnected? Is the temperature sensor connector correctly inserted?
ⓘ E 11	Rinse temperature sensor out of order (only on machines with temperature sensor on the rinse circuit)
	Is the temperature sensor short-circuited?

WARNING:

Alarms **E 2**, **E 6** and **E 7** lock the boiler temperature control.

Alarms **E 3**, **E 4** and **E 5** lock the tank temperature control.

In the case of alarms **E 6** and **E 7**, the boiler waiting phase is not executed (the rinse may be performed with cold water) and, during the initial warm-up and subsequent rinses (**bLF** > **0**), the boiler heating phase is not executed.

In the case of an open probe error (**E 4**, **E 6** e **E 10**), the displayed temperature is 10°C

In the case of a shorted probe error (**E 5**, **E 7** e **E 11**), the displayed temperature is 99°C.

E 1	Communication error
	Is the connection between main board and control panel correct? Are the connectors correctly connected? Are connector contacts clean?
E 2	Tank temperature low
	Does the tank heating element work properly? Are the connectors correctly connected? Are the dishwasher feed voltage and current correct? Is the relay RL5 on the board disconnected or faulty?
E 3	Boiler temperature low
	Does/do the boiler heating element/s work properly? Are the connectors correctly connected? Does the possible remote control switch connected to the heating element work correctly? Is there power at the remote control switch input terminals? Does relay RL2 on the board work properly? CAUTION: IF THERE IS A MALFUNCTION ON RELAY RL2 AND THE BOILER HEATING ELEMENTS ARE FED BY MEANS OF A REMOTE CONTROL SWITCH, THE BOARD DOES NOT HAVE TO BE REPLACED; JUST MOVE THE BOILER HEATING ELEMENT CONNECTOR TO ONE OF THE TWO FREE POSITIONS ON THE BOARD. CAUTION: WHEN ONE BRANCH OF THE HEATING ELEMENT DOES NOT WORK AND THE OTHER TWO CONTINUE TO FUNCTION, ON REACHING THE SET TEMPERATURE VALUE, ALARM 3 DISAPPEARS AND REAPPEARS IN THE SUBSEQUENT RINSE PHASE. THIS ALSO OCCURS WHEN A PHASE IS MISSING.



13.3 ALARMS THAT DON'T STOP THE DISHWASHER FOR MODELS WITH INCORPORATED CONTINUOUS WATER SOFTENER

If alarm **F21** or **F22** appears, the machine indicates it on the display at regular intervals and auto-configures itself in the same way as a machine without water softener. Resin regeneration cycles are not performed and the column used for filling is always the same (column B).

Alarm **F21** is reset when the machine is switched off and on from the mains switch (only if the causes that generated it have been eliminated).

Alarm **F22** is reset when the machine is switched off and on from the user interface or from the main switch (only if the causes that generated it have been eliminated).

WARNING:

Alarms marked with the Θ symbol from Serial Number 821 have become alarms which do not lock the machine.

Θ F21	Water softener operation errors
	This alarm appears in case of malfunctioning in the continuous water softener. To reset error F21 it is necessary to disconnect and reconnect the main power supply to the machine by means of the main switch on the external power board.
Θ F22	Communication errors between the mother board and softener board
	This alarm appears in case of problems in communication between the mother board and water softener board; check the connection between mother board connector J1 and water softener connector ST8

To facilitate the finding of faults signalled by alarm **F21**, another parameter providing a more detailed indication of the possible cause of malfunction has been introduced in the **r00** family (see table below).

To reset error **F21 it is necessary to disconnect and reconnect the main power supply to the machine by means of the main switch on the external power board.**

F21 1	Water softener conductivity sensor short-circuit
	Two or more water softener conductivity sensors are short-circuited. Check the connections between the water softener board and sensors, replacing the connection wiring if necessary.
F21 2	Water softener conductivity sensors open
	One or more water softener conductivity sensors are disconnected. Check the connections between the water softener board and sensors, replacing the connection wiring if necessary.
F21 3	Resin temperature sensor malfunction
	Replace the water softener electronic board.



F21 4	Water softener electronic board malfunction
	Replace the water softener electronic board.
F21 9	Salt water filling malfunction
(F21 6 up to version 4.01)	<p>The salt water container in the water softener was not completely filled within the set max. filling time.</p> <p>Make sure:</p> <ul style="list-style-type: none"> - the water cock is open - the water filling solenoid valve works correctly - the salt container solenoid valve works correctly - the feed water pressure is at least 50 kPa / 0.5 bar - the water inlet filter is clean - the filling solenoid valve filter is clean - the salt container cap is properly closed - the mother board (ATM-PRES) connector CN2 is correctly positioned - the water softener board connector ST5 is correctly positioned - the grille on the bottom of the salt container is clogged with dirt.
F21 10	Inefficient resin washing
	<p>After carrying out the maximum permissible number of resin washes, the resins are not sufficiently cleaned by the salt water used to regenerate them.</p> <p>Make sure:</p> <ul style="list-style-type: none"> - the water filling solenoid valve works correctly - the feed water pressure is at least 50 kPa / 0.5 bar - the water inlet filter is clean - the filling solenoid valve filter is clean - the mother board (ATM-PRES) connector CN2 is correctly positioned.

14 LIST OF PARAMETERS FOR SUBSEQUENT VERSIONS

The parameters listed below, even if present inside the software, cannot be used in appliances currently in production.

Family **GE**:

- parameter **REd**
- value **dEt = 183**

Family **St**:

Family **CFG** - alarm **F8**

- parameter **RRG**, the maximum value it can be set to is 3, but actually the only significant values are 0 and 1. By setting **RRG** to 3, alarm F8 may appear, also implemented by the firmware, but not used in any current application.



Electrolux

EFS - Dishwashing Systems Platform

Electrolux Professional
